

# **MathWorks 10**

## **Workbook**

Copyright Pacific Educational Press 2010

ISBN 978-1-89576-694-3

All rights reserved. No part of this publication may be reproduced, stored in a retrieval system, or transmitted in any form or by any means, electronic, mechanical, photocopying, recording, or otherwise without the prior written permission of the publisher.

#### Writer

Katharine Borgen, Vancouver School Board and University of British Columbia

#### Consultants

Katharine Borgen, PhD, Vancouver School Board and University of British Columbia

Jordie Yow, Mathematics Reviewer

#### Design, Illustration, and Layout

Sharlene Eugenio

Five Seventeen

#### Editing

Catherine Edwards

David Gargaro

Leah Giesbrecht

Nadine Pedersen

Katrina Petrik

#### Photographs

Cover photo courtesy Colin Pickell;

Men fixing stairs: Leah Giesbrecht;

Woman measuring fabric: Sharlene Eugenio;

Surveyor: Jacqueline Chandler/ Public domain/ Wikimedia Commons/ FEMA-42251;

Man mowing lawn: Selmer Van Alten/ [www.flickr.com](http://www.flickr.com);

Veterinarian: Veronica Pierce/ Public domain/ Wikimedia Commons/ VIRIN 050722-F-3177P-047;

Chapter 1: ©Jean-marie Guyon | Dreamstime.com;

Chapter 2: Courtesy U.S. Army Element Assembled Chemical Weapons Alternatives;

Chapter 3: Courtesy Ashlea Earl-Robinson;

Chapter 4: Morgan M. Wayling;

Chapter 5: Photo by Gary Schotel, Quesnel, BC;

Chapter 6: Leah Giesbrecht;

Chapter 7: Leah Giesbrecht.



Printed and bound in Canada.

# Contents

How to Use this Book 7

## 1 Unit Pricing and Currency Exchange 9

- 1.1 Proportional Reasoning 9
- 1.2 Unit Price 26
- 1.3 Setting a Price 36
- 1.4 On Sale! 49
- 1.5 Currency Exchange Rates 59
- Chapter Test 70

## 2 Earning an Income 74

- 2.1 Wages and Salaries 74
- 2.2 Alternative Ways to Earn Money 87
- 2.3 Additional Earnings 97
- 2.4 Deductions and Net Pay 106
- Chapter Test 114

## 3 Length, Area, and Volume 118

- 3.1 Systems of Measurement 118
- 3.2 Converting Measurements 131
- 3.3 Surface Area 142
- 3.4 Volume 158
- Chapter Test 169

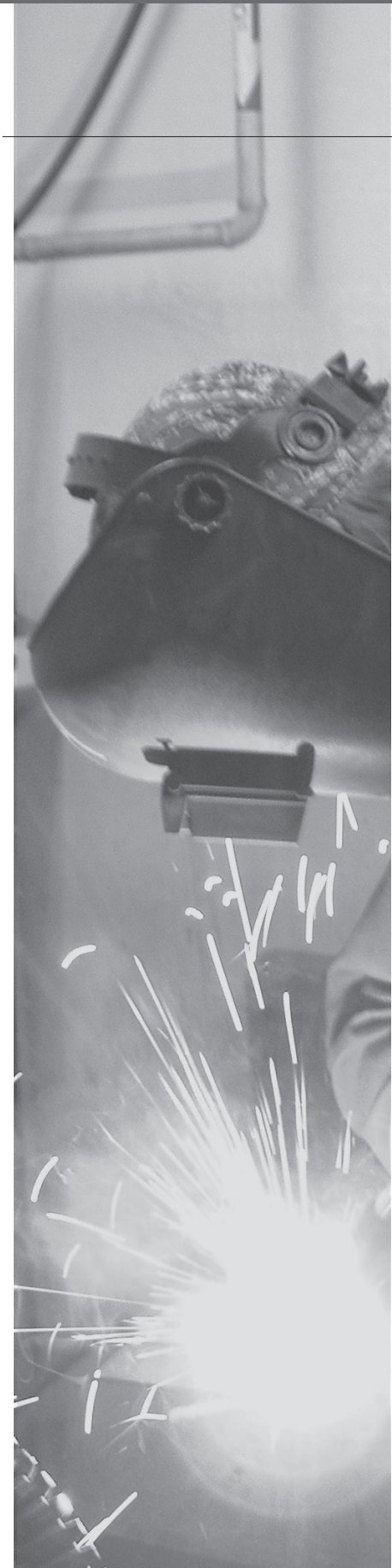



**4** **Mass, Temperature, and Volume** 175

- 4.1 Temperature Conversions 175
- 4.2 Mass in the Imperial System 183
- 4.3 Mass in the Système International 195
- 4.4 Making Conversions 203
- Chapter Test 210

**5** **Angles and Parallel Lines** 214

- 5.1 Measuring, Drawing, and Estimating Angles 214
- 5.2 Angle Bisectors and Perpendicular Lines 225
- 5.3 Non-Parallel Lines and Transversals 231
- 5.4 Parallel Lines and Transversals 239
- Chapter Test 248

**6** **Similarity of Figures** 253

- 6.1 Similar Polygons 253
- 6.2 Determining if Two Polygons Are Similar 265
- 6.3 Drawing Similar Polygons 271
- 6.4 Similar Triangles 277
- Chapter Test 284

**7** **Trigonometry of Right Triangles** 288

- 7.1 The Pythagorean Theorem 288
- 7.2 The Sine Ratio 297
- 7.3 The Cosine Ratio 308
- 7.4 The Tangent Ratio 318
- 7.5 Finding Angles and Solving Right Triangles 324
- Chapter Test 336

Glossary 340

Answer Key 342

## How to Use This Book

This workbook is a companion to *MathWorks 10* student resource, the authorized resource for the WNCP course, Apprenticeship and Workplace Mathematics. The *MathWorks 10 Workbook* is a valuable learning tool when used in conjunction with the student resource, or on its own. It emphasizes mathematical skill-building through worked examples and practice problems.

Here, you will learn and use the practical mathematics required in the workplace. Whether you plan to enroll in college, learn a trade, or enter the workforce after graduating from secondary school, the mathematical skills in this workbook will support you at work and in your daily life.

The *MathWorks 10 Workbook* contains seven chapters. Chapters are divided into sections, each focussing on a key mathematical concept. Each chapter includes the following features.

### **Review**

Each chapter opens with a review of mathematical processes and terms you will need to understand to complete the chapter's lessons. Practice questions are included.

### **Example**

Each example includes a problem and its solution. The problem is solved step by step. Written descriptions of each mathematical operation used to solve the problem are included.

### **New Skills**

The chapter's core mathematical concepts are introduced here. This section often includes real-world examples of where and how the concepts are used.

### **Build Your Skills**

This is a set of mathematical problems for you to solve. It appears after each new concept is introduced and will let you practise the concepts you have just learned about. Build Your Skills questions often focus on workplace applications of mathematical concepts.

### **Practise Your New Skills**

The section's key concepts are presented as review problems at the end of each chapter section.

### **Chapter Test**

At the end of each chapter, a chapter test is provided for review and assessment of learning.

### **Definitions**

New mathematical terms are defined in the sidebar columns. They are also included in the glossary at the back of the book.

### **Answer Key**

An answer key to this workbook's questions is located at the back of the book.

### **Glossary**

Definitions for mathematical terms are provided here. To increase understanding, some glossary definitions include illustrations.



# Chapter 1

---

## Unit Pricing and Currency Exchange



*Canadian wheat is processed into flour and sold nationally, where most of it becomes baked goods. Canada also exports about 20 million tonnes of its wheat and grain each year.*

### Proportional Reasoning

### 1.1

#### REVIEW: WORKING WITH FRACTIONS

In this section, you will use fractions to solve for unknown values.

**Example 1**Simplify  $\frac{18}{27}$ .**SOLUTION**

**factor:** one of two or more numbers that, when multiplied together, form a product. For example, 1, 2, 3, and 6 are factors of the product 6 because:

$$1 \times 6 = 6$$

$$2 \times 3 = 6$$

$$3 \times 2 = 6$$

$$6 \times 1 = 6$$

To simplify a fraction, state the fraction in its lowest terms. To find the lowest terms, divide the numerator and the denominator by their largest common **factor**.

$$\frac{18}{27} \leftarrow \begin{array}{l} \text{numerator} \\ \text{denominator} \end{array}$$

Identify the factors of 18 and 27.

$$18 = \{1, 2, 3, 6, 9, 18\}$$

$$27 = \{1, 3, 9, 27\}$$

The largest factor common to both 18 and 27 is 9. Divide both the numerator and the denominator by 9.

$$\frac{18}{27} = \frac{18 \div 9}{27 \div 9}$$

$$\frac{18 \div 9}{27 \div 9} = \frac{2}{3}$$

$$\frac{18}{27} = \frac{2}{3}$$

**ALTERNATIVE SOLUTION**

Using the largest common factor when simplifying fractions takes the least number of steps, but you can use any common factor.

$$\frac{18}{27} = \frac{18 \div 3}{27 \div 3}$$

Simplify, using the factor 3.

$$\frac{18 \div 3}{27 \div 3} = \frac{6}{9}$$

$$\frac{18}{27} = \frac{6}{9}$$

$$\frac{6}{9} = \frac{6 \div 3}{9 \div 3}$$

Simplify further, again using the factor 3.

$$\frac{6 \div 3}{9 \div 3} = \frac{2}{3}$$

$$\frac{6}{9} = \frac{2}{3}$$

The fractions  $\frac{18}{27}$ ,  $\frac{6}{9}$ , and  $\frac{2}{3}$  are equivalent fractions because they represent the same amount.



**BUILD YOUR SKILLS**

1. Simplify these fractions to their lowest terms.

a)  $\frac{4}{16} =$

b)  $\frac{3}{12} =$

c)  $\frac{25}{75} =$

d)  $\frac{15}{21} =$

e)  $\frac{8}{18} =$

f)  $\frac{45}{100} =$

g)  $\frac{20}{50} =$

h)  $\frac{3}{21} =$

i)  $\frac{7}{56} =$

**Example 2**

Solve for  $x$  in this equation containing fractions.

$$\frac{x}{16} = \frac{5}{24}$$

**SOLUTION**

To solve an equation, the same operation must be applied to both sides of the equation.

Begin by multiplying both sides of the equation by the same number so that you can clear it of fractions (by eliminating the denominators). This will allow you to isolate  $x$ .

The simplest multiplier is the lowest common denominator of the two fractions.

Identify the **multiples** of 16 and 24.

$$16 = \{16, 32, 48, 64, 80, \dots\}$$

$$24 = \{24, 48, 72, 96, \dots\}$$

**multiple:** the product of a number and any other number. For example, 2, 4, 6, and 8 are some multiples of 2 because:

$$2 \times 1 = 2$$

$$2 \times 2 = 4$$

$$2 \times 3 = 6$$

$$2 \times 4 = 8$$

The lowest common multiple between 16 and 24 is 48, so begin solving the equation by multiplying both fractions by 48.

$$\frac{x}{16} = \frac{5}{24}$$

$$48 \times \frac{x}{16} = \frac{5}{24} \times 48 \quad \text{Multiply by 48.}$$

$$\frac{48x}{16} = \frac{240}{24} \quad \text{Simplify.}$$

$$3x = 10$$

$$\frac{3x}{3} = \frac{10}{3} \quad \text{Divide by 3 to isolate } x.$$

$$x = \frac{10}{3} \text{ or } 3\frac{1}{3}$$

#### ALTERNATIVE SOLUTION

You did not need to use 48 as your multiplier. Any common multiple will work, and people often choose to multiply by the product of the denominators.

In this question, the product would be 16 multiplied by 24. You will get the same answer in the end, but you will work with larger numbers.

$$\frac{x}{16} = \frac{5}{24}$$

$$(24 \times 16) \times \frac{x}{16} = \frac{5}{24} \times (16 \times 24) \quad \text{Multiply both sides by the product of the denominators.}$$

$$384 \times \frac{x}{16} = \frac{5}{24} \times 384 \quad \text{Simplify.}$$

$$\frac{384x}{16} = \frac{1920}{24}$$

$$24x = 80$$

$$\frac{24x}{24} = \frac{80}{24} \quad \text{Divide both sides by 24 to isolate } x.$$

$$x = \frac{80}{24}$$

$$x = \frac{80 \div 8}{24 \div 8} \quad \text{Simplify, using the factor 8.}$$

$$x = \frac{10}{3} \text{ or } 3\frac{1}{3} \text{ or } 3.\bar{3}$$

If  $x$  is not a whole number, it is best to leave the answer as a fraction or in mixed numeral form rather than as a decimal because the decimal answer would often have to be rounded.

**BUILD YOUR SKILLS**2. Solve for  $x$ .

a)  $\frac{x}{10} = \frac{40}{50}$

b)  $\frac{12}{16} = \frac{18}{x}$

c)  $\frac{56}{64} = \frac{x}{8}$

d)  $\frac{18}{27} = \frac{36}{x}$

e)  $\frac{x}{2056} = \frac{3}{4}$

f)  $\frac{3}{12} = \frac{15}{x}$

g)  $\frac{3}{5} = \frac{x}{460}$

h)  $\frac{25}{x} = \frac{40}{200}$

## NEW SKILLS: WORKING WITH RATIO AND PROPORTION

**ratio:** a comparison between two numbers measured in the same units

When a carpenter bonds two pieces of wood with epoxy resin, she must first mix the epoxy with a hardener. She mixes these materials in a **ratio** of 10 to 1, where there are 10 parts of epoxy to 1 part of hardener. This ratio can be written as 10:1 or as a fraction,  $\frac{10}{1}$ .

If the carpenter wanted to use 150 parts of epoxy, she would need 15 parts of hardener. This would give her a ratio of 150 to 15 between the amount of epoxy and the amount of hardener. You can write this as 150:15 or as  $\frac{150}{15}$ .

The ratio  $\frac{150}{15}$  can be simplified to  $\frac{10}{1}$ .

$$\frac{150}{15} = \frac{150 \div 15}{15 \div 15}$$

$$\frac{150 \div 15}{15 \div 15} = \frac{10}{1}$$

$$\frac{150}{15} = \frac{10}{1}$$

It is common to express ratios as fractions when doing calculations.

**proportion:** a fractional statement of equality between two ratios

When you state that two ratios are equal, as they are in the following equation, you have written a **proportion**.

$$\frac{150}{15} = \frac{10}{1}$$

For more information, see page 12 of *MathWorks 10*.

**Example 3**

Charles works as a cook in a restaurant. His chicken soup recipe contains:

- 11 cups of seasoned broth
- 5 cups of diced vegetables
- 3 cups of rice
- 3 cups of chopped chicken

He wants to make the recipe at home for his parents. To reduce the recipe yield, he needs to know what the ratios are between the quantities of ingredients.

- a) What is the ratio of vegetables to chicken?
- b) What is the ratio of broth to vegetables?
- c) What is the ratio of chicken to rice?
- d) What is the ratio of the chicken to the total ingredients in the recipe?

**SOLUTION**

- a) Since there are 5 cups of vegetables and 3 cups of chicken, the ratio of vegetables to chicken is 5:3 or  $\frac{5}{3}$ .
- b) Since there are 11 cups of broth and 5 cups of vegetables, the ratio of broth to vegetables is 11:5 or  $\frac{11}{5}$ .
- c) There are 3 cups of chicken and 3 cups of rice, so the ratio of chicken to rice is 3:3 or  $\frac{3}{3}$ . This can be simplified to 1:1 or  $\frac{1}{1}$ .
- d) There are 3 cups of chicken in the recipe, and a total of 22 cups of ingredients. The ratio of chicken to the total amount of ingredients is 3:22 or  $\frac{3}{22}$ .

A ratio can have a numerator larger than the denominator. Because a ratio compares two numbers, do not rewrite it as a mixed fraction.

Although  $\frac{1}{1}$  is usually written as the number 1, keep it as a fraction when it is a ratio comparing two numbers.

**BUILD YOUR SKILLS**

3. For a silk screening project, Jan mixes a shade of orange ink. She uses a ratio of red ink to yellow ink of 2:3 and yellow ink to white ink of 3:1.
  - a) How many mL of yellow ink would she need if she used 500 mL of white ink?
  
  
  
  
  
  
  
  
  
  
  - b) How many mL of red ink would she need if she used 750 mL of yellow ink?
  
  
  
  
  
  
  
  
  
  
4. On a bicycle with more than one gear, the ratio between the number of teeth on the front gear and the number of teeth on the back gear determines how easy it is to pedal. If the front gear has 30 teeth and the back gear has 10 teeth, what is the ratio of front teeth to back teeth?
  
  
  
  
  
  
  
  
  
  
5. Some conveyor belts have two pulleys. If one pulley has a diameter of 45 cm and another has a diameter of 20 cm, what is the ratio of the smaller diameter to the larger diameter?

6. Bank tellers use ratios when converting currencies. If \$1.00 CAD equals approximately 1.13 Australian dollars, what is the ratio of Canadian dollars to Australian dollars?
  
  
  
  
  
  
  
  
  
  
7. What is the ratio of 250 mL of grape juice concentrate to 1 L of water? (Hint: Convert both measurements to the same units. There are 1000 mL in 1 L.)
  
  
  
  
  
  
  
  
  
  
8. A mechanic mixes oil with gas to lubricate the cylinders in a motorcycle engine. He uses 1 part oil and 32 parts gas. What is the ratio of oil to gas?

---

**Example 4**

Tom and Susan make \$180.00 from holding a garage sale. Because Tom contributed fewer items to the sale, the money is to be divided between Tom and Susan in the ratio of 1:2. How much money will each person receive?

**SOLUTION**

Since the ratio is 1:2, this means that for every \$1.00 Tom receives, Susan receives \$2.00. Stated another way, this means that for every \$3.00 earned, Tom gets \$1.00 and Susan gets \$2.00.

Therefore, Tom receives  $\frac{1}{3}$  of the money and Susan receives  $\frac{2}{3}$  of it.

$$\frac{1}{3} \times 180 = 60$$

$$\frac{2}{3} \times 180 = 120$$

Tom gets \$60.00 and Susan gets \$120.00.



**BUILD YOUR SKILLS**

9. The ratio of flour to shortening in a recipe for piecrust is 2:1. If a baker makes 30 cups of piecrust, how many cups of flour and shortening does he use?
10. A compound of two chemicals is mixed in the ratio of 3:10. If there are 45 litres of the compound, how much of each chemical is in the mixture?
11. Cheryl is an automotive repair technician. She mixes paint and thinner to apply to a bus. The instructions say to mix paint with thinner in the ratio of 5:3. If Cheryl needs 24 L of paint/thinner mixture, how much of each will she use?

**NEW SKILLS: WORKING WITH RATE**

A **rate** is a ratio comparing two numbers measured in different units.

Some examples of rates are:

- \$1.69/100 g or  $\frac{\$1.69}{100 \text{ g}}$  for the cost of ham at the deli
- 80 km/h or  $\frac{80 \text{ km}}{1 \text{ h}}$  for how fast a car travels
- \$38.00/4 h or  $\frac{\$38.00}{4 \text{ h}}$  for how much you earn at work

For more information, see page 17 of *MathWorks 10*.

**rate:** a comparison between two numbers measured with different units

**Example 5**

The amount of fuel consumed by a vehicle when it is driven 100 km is referred to as the rate of fuel consumption. Write a rate statement that indicates that a car uses 6.3 litres of gas for every 100 km driven.

**SOLUTION**

$$6.3 \text{ L}:100 \text{ km}, \frac{6.3 \text{ L}}{100 \text{ km}}, \text{ or } 6.3 \text{ L}/100 \text{ km}$$

**BUILD YOUR SKILLS**

- Write a rate statement that indicates that you earned \$65.00 interest on your investment in the last 3 months.
- Write a rate statement that indicates how much you earn in an 8-hour day if you are paid \$9.25 for each hour you work.
- Write a rate statement that indicates that 1 cm on a map represents 2500 km in real distance.

**Example 6**

If you earn \$150.00 in 12 hours, how much will you earn if you work 40 hours?

**SOLUTION**

$$\frac{\$150.00}{12 \text{ h}} = \frac{\$x}{40 \text{ h}}$$

$$\frac{150}{12} = \frac{x}{40}$$

In your calculation, omit the units.

$$(12 \times 40) \times \frac{150}{12} = \frac{x}{40} \times (40 \times 12)$$

Multiply both sides of the equation by the product of the denominators.

$$480 \times \frac{150}{12} = x \times 480$$

Simplify.

$$40 \times 150 = x \times 12$$

$$6000 = 12x$$

$$\frac{6000}{12} = \frac{12x}{12}$$

Divide both sides by 12 to isolate  $x$ .

$$\frac{6000}{12} = x$$

$$500 = x$$

You will earn \$500.00 in 40 hours.

**BUILD YOUR SKILLS**

15. If a type of salami at the deli costs \$1.59 per 100 g, how much will you pay for 350 g?

16. As a janitor, Janine makes a cleaning solution by mixing 30 g of concentrated powdered cleanser into 2 L of water. How much powder will she need for 5 L of water?
17. An office has decided to track how much paper it uses to reduce waste. At the end of each month, the secretary records the total number of sheets used and their weight. If paper weighs 4.9 kg for every 500 sheets, how much will 700 sheets weigh?

**PRACTISE YOUR NEW SKILLS**

1. Find the unknown value in each of the following proportions. Give answers to the nearest tenth of a unit (to one decimal place).

a)  $\frac{24}{18} = \frac{x}{12}$

b)  $\frac{168 \text{ km}}{2 \text{ h}} = \frac{548 \text{ km}}{x \text{ h}}$

While calculating,  
omit the units.

c)  $\frac{40}{28} = \frac{60}{x}$

d)  $\frac{6 \text{ pizza slices}}{2 \text{ people}} = \frac{x \text{ pizza slices}}{21 \text{ people}}$

e)  $\frac{87 \text{ blankets}}{x \text{ bundles}} = \frac{24 \text{ blankets}}{8 \text{ bundles}}$

f)  $\frac{12}{25} = \frac{25}{x}$

g)  $\frac{7}{15} = \frac{x}{1}$

h)  $\frac{12}{45} = \frac{16}{x}$

2. A hairdresser mixes brunette hair colouring for a client using 20 mL hair colour, 40 mL colour developer, 15 mL conditioner, and 3 mL thickener. Find the following ratios and simplify them to their lowest terms. Express your answers as fractions.

a) The ratio of hair colour to thickener.

- b) The ratio of thickener to conditioner.
- c) The ratio of colour developer to hair colour.
- d) If this treatment costs the customer \$68.00 and the cost of labour and materials used is \$14.20, what is the ratio of customer price to actual cost?
3. If the ratio of yellow pigment to blue pigment in a shade of green paint is 2:3, how many drops of yellow pigment will be needed if 12 drops of blue are used?

4. If 5 cm on a map represents 2.5 km of actual ground, how many centimetres would 15 km of actual ground be on the map?
  
  
  
  
  
  
  
  
  
  
  
  
  
  
  
5. If a can of paint will cover  $48 \text{ m}^2$  of wall space, how many cans will you need to paint  $220 \text{ m}^2$ ?
  
  
  
  
  
  
  
  
  
  
  
  
  
  
  
6. The ratio of teeth on a pair of driving gears is  $13:6$ , with the larger gear having more teeth. If the larger gear has 52 teeth, how many does the smaller gear have?





## 1.2

## Unit Price

## NEW SKILLS: WORKING WITH UNIT PRICE

**unit price:** the cost of one unit; a rate expressed as a fraction in which the denominator is 1

When items are sold in quantities of more than 1, the **unit price** indicates how much 1 of the items would cost. For example, if you buy a package of 3 pencils, the unit price is the price of 1 pencil.

For more information, see page 23 of *MathWorks 10*.

## Example 1

If a carton of one dozen eggs costs \$3.29, how much are you paying for 1 egg?

## SOLUTION

Solve using a proportion. Let  $x$  represent the cost of 1 egg.

$$\frac{\$3.29}{12 \text{ eggs}} = \frac{x}{1 \text{ egg}}$$

$$\frac{3.29}{12} = \frac{x}{1}$$

Omit the units in the calculation.

$$12 \times \frac{3.29}{12} = \frac{x}{1} \times 12$$

Multiply both sides of the equation by 12.

$$3.29 = 12x$$

Simplify.

$$\frac{3.29}{12} = \frac{12x}{12}$$

Divide both sides by 12 to isolate  $x$ .

$$\frac{3.29}{12} = x$$

$$0.27 \approx x$$

One egg costs approximately \$0.27.



People often think that larger-sized packages cost less per unit, but this is not always so.

**Example 2**

Often unit price is used to compare costs.

A 48-oz can of tomatoes costs \$2.99. An 18-oz can costs \$1.19. Which is a better buy?

**SOLUTION**

Calculate the cost of 1 oz of tomatoes for each size of can.

Calculate the cost of 1 oz from the 48-oz can.

$$\$2.99 \div 48 \approx \$0.062 \quad \text{Divide the total cost by the total number of ounces.}$$

1 oz of tomatoes costs approximately \$0.06.

Calculate the cost of 1 oz from the 18-oz can.

$$\$1.19 \div 18 \approx \$0.066 \quad \text{Divide the total cost by the total number of ounces.}$$

1 oz of tomatoes costs approximately \$0.07.

It costs more for one ounce of tomatoes from the 18-oz can, so the 48-oz can is the better buy.



**Example 3**

Shirin is the manager of a fabric store and is training a new employee. Shirin wants to make an easy reference chart that lists the prices of different lengths of a fabric. One metre of the fabric costs \$8.42. Fill in the rest of the chart.

<b>FABRIC COST BY LENGTH</b>	
<i>Length of fabric</i>	<i>Cost of fabric</i>
0.5 m	
1 m	\$8.42
1.75 m	

**SOLUTION**

You can solve this using proportions. First find the cost of 0.5 m.

$$\frac{\$8.42}{1 \text{ m}} = \frac{\$x}{0.5 \text{ m}}$$

$$\frac{8.42}{1} = \frac{x}{0.5}$$

Omit the units during calculations.

$$0.5 \times 8.42 = \frac{x}{0.5} \times 0.5 \quad \text{Multiply both sides of the equation by the product of the denominator, 0.5.}$$

$$0.5 \times 8.42 = x \quad \text{Simplify.}$$

$$4.21 = x$$

The cost of 0.5 m of fabric is \$4.21.

Then find the cost of 1.75 m.

$$\frac{8.42}{1} = \frac{x}{1.75}$$

$$1.75 \times 8.42 = \frac{x}{\cancel{1.75}} \times \cancel{1.75}$$

$$1.75 \times 8.42 = x$$

$$14.74 = x$$

<b>FABRIC COST BY LENGTH</b>	
<i>Length of fabric</i>	<i>Cost of fabric</i>
0.5 m	\$4.21
1 m	\$8.42
1.75 m	\$14.74

**ALTERNATIVE SOLUTION**

You can use unit rates rather than proportions.

1 m costs \$8.42. Use this unit cost to calculate the cost of the other lengths

$$\$8.42 \times 0.5 = \$4.21$$

$$\$8.42 \times 1.75 = \$14.74$$

**BUILD YOUR SKILLS**

7. Sasha is a landscape gardener. He sees that a 200-foot roll of string trimmer line costs \$18.75. A 150-foot roll of line costs \$15.21.
- a) Which roll of line is the least expensive per foot?
- b) What is the difference in price, per foot?
8. If  $2\frac{1}{2}$  kg of tomatoes cost \$8.25, how much will you pay for 7 kg?
9. If Wayne bought 5 litres of gas for his lawnmower for \$5.45, how much would he have to pay to fill his car with 48 litres of gas?



**PRACTISE YOUR NEW SKILLS**

1. During the summer, Dean works as a cashier in a store near Saskatchewan's Greenwater Lake Provincial Park. The store sells a case of 12 bottles of water for \$8.50 and individual bottles of the same brand of water for \$1.55.
  - a) Approximately how much does each bottle of water in the case of 12 cost?
  
  
  
  
  
  
  
  
  
  
  - b) How much would a customer save by buying a case of water, rather than 12 individual bottles?
  
  
  
  
  
  
  
  
  
  
2. Maureen purchased enough carpet to cover a rectangular room measuring 7 metres by 12 metres. The carpet costs \$8.15 per square metre.
  - a) How much carpet did Maureen buy?
  
  
  
  
  
  
  
  
  
  
  - b) How much did the carpet cost?

3. Tyler is a self-employed sheet metal worker. He purchases 25 sheets of aluminum that measure 4 feet by 8 feet. The cost is \$4000.00 before tax and shipping.

a) How much does 1 sheet cost?

b) What is the price per square foot?

4. A painting business buys 3-inch wide paintbrushes from a supplier in cases of 6. One case costs \$31.29.

a) How much do two brushes cost?

b) If a customer buys two or more cases, the supplier reduces the price of the case by 10 percent. How much would 3 cases of paintbrushes cost? How much would each brush cost?

5. Which is the better buy: 8 ounces of Brie cheese for \$4.95 or 12 ounces for \$7.49?
6. Debbie is a cook in a restaurant that is open 6 days a week. She is responsible for recording and monitoring the amount of money she spends on food. In the summer, she uses an average of 9 loaves of bread per day.
- a) On average, how many loaves of bread does Debbie use each week?
- b) If bread costs \$1.25 per loaf to buy from a wholesale distributor, how much money should Debbie budget to purchase it, for the month of June? Assume that there are just 4 weeks in June.

7. The cost of a 355-mL can of juice is \$1.25 in a vending machine. A 1.89-L carton of the same juice costs \$3.89 at the grocery store. How much would you save per mL if you bought juice from the grocery store instead of the vending machine? (Hint: 1 L equals 1000 mL.)
8. Patricio is ordering cartons of detergent for resale in his store. He can order a carton of 12 for \$34.68 plus \$5.45 for delivery, or a carton of 18 for \$51.30 plus \$6.25 for delivery. Which is a better buy, and by how much per unit?

## 1.3

## Setting a Price

**REVIEW: WORKING WITH PERCENTS AND DECIMALS**

In this section, you will calculate percentages and convert between percents and decimals.

**Example 1**

Convert 65% to a decimal.

**percentage:** a ratio with a denominator of 100; percent (%) means "out of 100"

Dividing by 100 gives the same result as moving the decimal two places to the left. Many people use this as a shortcut.

**SOLUTION**

To convert a **percentage** to a decimal, first convert it to a fraction with a denominator of 100, then divide the numerator by the denominator.

65% means 65 out of 100, or, stated as a fraction,  $\frac{65}{100}$ .

Divide 65 by 100 to express 65% as a decimal.

$$65 \div 100 = 0.65$$

65% is equal to 0.65.

**BUILD YOUR SKILLS**

1. Convert the following percentages to decimals.

a) 78%

b) 93%

c) 125%

d) 324%

e) 0.5%

f) 0.38%

g) 1.2%

h) 100%

**Example 2**

Calculate 20% of 45.

**SOLUTION**

To find a percentage of a number, you can use proportional reasoning.

Let  $x$  represent 20% of 45. Use proportional reasoning to solve for  $x$ .

$$\frac{20}{100} = \frac{x}{45}$$

$$4500 \left( \frac{20}{100} \right) = \left( \frac{x}{45} \right) 4500$$

Multiply both sides of the equation by the product of the denominators.  
Simplify.

$$45 \times 20 = 100x$$

$$900 = 100x$$

$$\frac{900}{100} = \frac{100x}{100}$$

Divide both sides by 100 to isolate  $x$ .

$$9 = x$$

20% of 45 is 9.

**ALTERNATIVE SOLUTION**

First convert 20% to a decimal.

$$20 \div 100 = 0.20$$

Then calculate 20% of 45 by multiplying 0.20 by 45.

$$x = 0.20 \times 45$$

$$x = 9$$

**BUILD YOUR SKILLS**

2. Calculate the following percentages.

a) 15% of 300

b) 45% of 1500

c) 140% of 70

d) 175% of 24

e) 7.8% of 50

f) 0.3% of 175

g) 200% of 56

h) 135% of 25

If the percentage is larger than 100, then your answer will be larger than the number you started with.



**Example 3**

What percent is 5 of 20?

**SOLUTION**

To calculate what percent one number is of another means that you need to determine what number out of 100 is equivalent to your ratio.

You can use proportional reasoning to solve the question.

$$\begin{aligned}\frac{x}{100} &= \frac{5}{20} \\ 100 \times \frac{x}{100} &= \frac{5}{20} \times 100 && \text{Multiply both sides of the equation} \\ x &= 5 \times 5 && \text{by 100.} \\ x &= 25 && \text{Simplify.}\end{aligned}$$

5 is 25% of 20.

**ALTERNATIVE SOLUTION**

5 of 20 is the same as  $\frac{5}{20}$ . You can find the percent by dividing 5 by 20.

$$5 \div 20 = 0.25$$

This is 25 hundredths, or 25%.

**BUILD YOUR SKILLS**

3. Calculate what percentage the first number is of the second (to the nearest tenth of a percent).

a) 65 of 325

b) 135 of 405

c) 68 of 42

d) 13 of 65

e) 1 of 12

f) 625 of 50

**NEW SKILLS: WORKING WITH MARKUPS AND TAXES**

When a person owns a business, she usually buys merchandise at a wholesale price. She then sells it at a higher price, called a retail price, to make a profit. The retail price is often determined by adding a certain percentage of the wholesale price to the wholesale price. The amount added is referred to as the **markup**.

Sales taxes are usually added to the retail price. There are three kinds of taxes that you may need to consider when purchasing items: Goods and Services Tax (GST), Provincial Sales Tax (PST), and Harmonized Sales Tax (HST).

For more information, see page 28 of *MathWorks 10*.

**markup:** the difference between the amount a dealer sells a product for (retail price) and the amount he or she paid for it (wholesale price)

**Example 4**

Melanie owns a clothing store. Her standard markup is 85%. She bought a coat from the wholesaler at \$125.00.

- a) What would the markup be?
- b) How much would Melanie charge her customer for the coat?

**SOLUTION**

- a) Change 85% to a decimal.

$$85 \div 100 = 0.85$$

Multiply the wholesale price by the markup.

$$\$125.00 \times 0.85 = \$106.25$$

The markup is \$106.25.

- b) Melanie would charge her customer the wholesale price plus the markup.

$$\$125.00 + \$106.25 = \$231.25$$

With a markup of 85%, Marnie would charge her customer \$231.25.

**BUILD YOUR SKILLS**

4. The markup on a bicycle in a sporting goods store is 125%. The bicycle's wholesale price is \$450.00. What is the markup in dollars?

5. Marco buys a certain brand of shampoo from a supplier at \$7.25 per bottle. He sells it to his customers at a markup of 25%. What would the markup be?
6. A *hanbok* is a formal, traditional outfit of Korean clothing. At a markup of 60%, what would be the retail price for a child's *hanbok* with a wholesale price of \$117.45?
7. What should Max charge for a package of paper plates in his store if he bought them for \$9.00 and wants to make a 75% profit?

**Example 5**

Quentin wants to buy a pair of steel-toed boots listed at \$179.95. How much will the boots cost if 5% GST and 6% PST are charged?

**SOLUTION**

Calculate the GST by changing 5% to a decimal and multiplying by the retail price.

$$5 \div 100 = 0.05$$

$$0.05 \times \$179.95 = \$9.00$$

Calculate the PST by changing 6% to a decimal and multiplying by the retail price.

$$6 \div 100 = 0.06$$

$$0.06 \times \$179.95 = \$10.80$$

The final price is calculated by adding the tax amounts to the retail price.

$$\$179.95 + \$9.00 + \$10.80 = \$199.75$$

Quentin will have to pay \$199.75.

**ALTERNATIVE SOLUTION 1**

$$5\% + 6\% = 11\%$$

Add the two taxes together.

$$11 \div 100 = 0.11$$

Change to a decimal.

$$0.11 \times \$179.95 = \$19.79$$

Multiply to find 11% of the retail price.

$$\$179.95 + \$19.79 = \$199.74$$

Add the total tax to the retail price.

This is different than the first solution because rounding occurs at a different spot.

**ALTERNATIVE SOLUTION 2**

You can think about the retail price as 100% of the cost. If you add the two sales taxes (5% plus 6% equals 11%) to this, the total cost is 111%.

Convert 111% to a decimal and multiply this by the initial cost.

$$111 \div 100 = 1.11$$

$$\$179.95 \times 1.11 = \$199.74$$

While it is convenient for you to use the methods in Alternative Solutions 1 or 2, the store would have to use the first method because they must keep track of how much GST and PST they collect.



12. If the markup is 125% on a certain brand of jeans that have a wholesale price of \$30.00, what will the consumer pay, if GST and PST are each 5%?

13. The markup on a restaurant meal is 250%. A meal costs \$7.25 to produce. How much will the customer be charged, after markup and 5% GST are applied?

### **PRACTISE YOUR NEW SKILLS**

1. Calculate the following percentages.

a) 5% of 72

b) 275% of 8

c) 152% of 200

d)  $6\frac{3}{4}$ % of 700

2. An electrician buys his material at the local hardware store, then charges his customer 20% more. The material for a given project is \$253.75 at the hardware store.
  - a) What is the markup?
  
  
  
  
  
  
  
  
  
  
  - b) How much does he charge the customer for the material?
  
  
  
  
  
  
  
  
  
  
3. Maria is a florist in a small boutique. If Maria paid her supplier \$8.50/doz for roses and sold them for \$19.95, what was the percent markup?
  
  
  
  
  
  
  
  
  
  
4. Garth buys snow tires from a dealer in Thunder Bay, ON. The tires cost \$79.00 each. To make a profit, he must mark them up 40%. How much must a customer pay for 4 tires if there is a 12% HST on the final sale?



5. Because the cost of ingredients has gone up, Maurice has decided to increase the cost of meals in his restaurant by 12%. How much will he now charge for a grilled salmon fillet that used to cost \$17.95?
  
  
  
  
  
  
  
  
  
  
6. The wholesale cost of a certain brand of T-shirts is \$132.00/dozen. To cover costs and make a profit, Lorena marks them up by 75%. If GST is 5% and PST is 7%, what will a customer have to pay for 1 T-shirt?
  
  
  
  
  
  
  
  
  
  
7. An MP3 player that Harry wants to buy sells for \$89.95 in BC where there is 12% HST. When he is on holiday in Alberta (where there is only the 5% GST), Harry sees the same MP3 player for \$94.89. Which is a better buy and by how much?

**On Sale!**

1.4

**NEW SKILLS: SALE PRICES**

When you go shopping, you see signs that advertise **promotions**, such as “For Sale,” “Up to 50% Off,” and “Discounted Prices,” that mean you will pay less than the price on the tag.

For more information, see page 34 of *MathWorks 10*.

**promotion:** an activity that increases awareness of a product or attracts customers

**Example 1**

Samantha wants to buy a new TV. The model she likes costs \$675.95, but the clerk tells her that it is going on sale next week at 20% off. If Samantha waits one week, how much will she save on the price of the TV?

**SOLUTION**

The discount is 20%, so find 20% of \$675.95 by multiplication.

Convert 20% to a decimal.

$$20 \div 100 = 0.20$$

Multiply 0.20 by the original price.

$$0.20 \times \$675.95 = \$135.19$$

The original price will be discounted by this amount, so Samantha would save \$135.19.



**Example 2**

Michelle is a member of the Xat'sull First Nation and is fluent in the Shuswap language. She works as a language instructor and gift shop cashier at the Xat'sull Heritage Village, near Williams Lake, BC.

The gift shop is selling off summer inventory. What will be the cost of a carving that was priced at \$149.95 if the sale sign says “Reduced by 60%”?

**SOLUTION**

Calculate 60% of \$149.95 to determine the savings.

First, convert 60% to a decimal.

$$60 \div 100 = 0.60$$

Multiply the original price by 0.60.

$$0.60 \times \$149.95 = \$89.97$$

The original price will be reduced by this amount, so subtract \$89.97 from \$149.95.

$$\$149.95 - \$89.97 = \$59.98$$

The cost of the carving will be \$59.98.

**ALTERNATIVE SOLUTION**

If the price of the carving is reduced by 60%, that means that the customer will pay only 40% of the cost (100% minus 60% is 40%).

Convert 40% to a decimal.

$$40 \div 100 = 0.40$$

Multiply the original price by 0.40.

$$0.40 \times \$149.95 = \$59.98$$

The carving will cost \$59.98.



**Example 3**

Lisa specializes in selling products from the Philippines, including rattan, bamboo, and palm baskets. Medium-sized bamboo baskets are regularly priced at \$19.98. They are on sale, advertised as “Buy one, get the second at half price.” What is the discount rate, as a percent?

**SOLUTION**

Calculate the regular cost of 2 baskets.

$$\$19.98 \times 2 = \$39.96$$

In buying 2 baskets, you save half the price of 1 basket.

$$\frac{1}{2}(\$19.99) = \$9.99$$

Calculate the percent savings by dividing the discount by the regular price, and multiplying by 100.

$$\frac{\$9.99}{\$39.96} \times 100\% = 25\%$$

The discount rate is 25%.



10. Shelly works as an optician in Whitehorse, YT. Her store is selling last year's glasses frames at a savings of 30%. What will you pay for frames that were originally priced at \$149.00 if 5% GST is charged?

GST and PST are paid on the selling price, not the original price.

11. Nicole wants to buy a coat originally priced at \$249.95. It is on sale at 25% off. How much will she pay if 5% GST and 5% PST are charged?

12. Yasmin owns a kitchen and bath fitting store. She is selling a kitchen sink at a reduction of 40% because of a scratch in the finish. The original price was \$249.95.

a) Determine the total savings to the customer, including 5% GST and a PST of 8%.

b) Calculate the percentage of savings.





4. A can of paint costs \$59.95. There is a 20% price reduction for contractors. How much will the contractor save if he buys 5 cans?
5. A furniture store offers a “Closing Out Sale: Everything 80% Off.”
- a) How much will you pay for a bedroom suite that originally cost \$2989.97 if GST is 5% and PST is 7%?
- b) What are your total savings on this purchase?
6. Robert sells bicycles, skateboards, and snowboards at his sporting goods store. A bicycle that was originally priced at \$785.00 sold for \$553.00. What percent markdown did Robert offer?

7. The wholesale cost of a *tawa*, a griddle used to cook Indian flatbread, is \$53.00. A merchant marks it up 65%. At the end of the season, he sells the remaining stock at 60% off.
- a) What was his original asking price?
  
  
  
  
  
  
  
  
  
  
  - b) At the original price, how much would a customer pay with 5% GST and 5% PST?
  
  
  
  
  
  
  
  
  
  
  - c) What was the end-of-season sale price?
  
  
  
  
  
  
  
  
  
  
  - d) How much would a customer pay when it was on sale, including 5% GST and 5% PST?
  
  
  
  
  
  
  
  
  
  
  - e) What would the total savings be if it were bought on sale?
  
  
  
  
  
  
  
  
  
  
  - f) What would be the percentage savings?

## Currency Exchange Rates

# 1.5

### NEW SKILLS: EXCHANGE RATES

Different countries use different monetary units and/or different currencies. It is important when travelling to consider **exchange rates**, or the value of one monetary unit compared to another.

For more information, see page 41 of *MathWorks 10*.

### Example 1

Lucas is a glazier who operates a window installation business. He regularly travels to the United States to buy supplies. Before travelling, he converts \$500.00 CAD into American dollars for personal expenses. If one Canadian dollar is worth 0.94192 of an American dollar, how many American dollars will Lucas receive in exchange for \$500.00 CAD?

#### SOLUTION

Use unit pricing.

$$\$1.00 \text{ CAD} = \$0.94192 \text{ USD}$$

$$\$500.00 \text{ CAD} = \$0.94192 \text{ USD} \times 500$$

$$\$500.00 \text{ CAD} = \$470.96 \text{ USD}$$

Lucas will receive \$470.96 USD.

**exchange rate:** the price of one country's currency in terms of another country's currency

Using approximation when working with exchange rates is useful if you want to quickly convert between currencies. You can think of the exchange rate in Example 1 as meaning that for every Canadian dollar, you will lose approximately 6 cents when converting to American dollars.



**Example 2**

One Thai baht is worth 0.023541 of a Canadian dollar. How many bahts would a tourist in Thailand receive for \$200.00 CAD?

**SOLUTION**

$$1.00 \text{ baht} = \$0.023541 \text{ CAD}$$

$$200 \div 0.023541 = 8495.82$$

For \$200.00 CAD, a tourist in Thailand would receive 8495.82 bahts.

**BUILD YOUR SKILLS**

4. If the exchange rate for converting a Canadian dollar to the euro is 0.7180 on a particular day, how many euros would you get for \$300.00 CAD?
  
  
  
  
  
  
  
  
  
  
5. The exchange rate for converting a Canadian dollar to the Swiss franc (SFr) is 1.0542. How many Swiss francs will you get for \$400.00 CAD?
  
  
  
  
  
  
  
  
  
  
6. Canada imports steel, iron, and organic and inorganic chemicals from Trinidad and Tobago. The exchange rate for converting the Canadian to the Trinidad and Tobago dollar is 6.1805. How many Trinidad and Tobago dollars will you get for \$200.00 CAD?

7. Using the following exchange rates, calculate how much foreign currency you would receive for \$200.00 CAD.
- a) \$1.00 CAD is worth 1.72904 Brazilian reals
  
  
  
  
  
  
  
  
  
  
  - b) \$1.00 CAD is worth 8.71137 Moroccan dirhams
  
  
  
  
  
  
  
  
  
  
  - c) \$1.00 CAD is worth 7.72277 Ukrainian hryvnia
  
  
  
  
  
  
  
  
  
  
  - d) \$1.00 CAD is worth 3.19889 Polish zloty
8. Calculate the value in Canadian dollars of an item that costs \$449.75 Singapore dollars. Assume the exchange rate for one Canadian dollar is 0.75529.

9. Henry returns home to Whale Cove, Nunavut, after a trip to Europe. On his travels he purchased a jacket for 125.98 euros. Calculate the value of Henry's jacket in Canadian dollars. Assume that a euro is worth 1.3987 of a Canadian dollar.
10. The exchange rate between the South African rand and the Canadian dollar is 0.138469 (1 rand equals \$0.138469 CAD). What is the cost in Canadian dollars of an item priced at 639.00 rand?

Exchanging money is not quite as simple as the transactions here show. Although the calculations will be the same, you have to consider bank buying rate and bank selling rate when exchanging currency. When the bank buys foreign currency from you, they pay you less than they charge when they sell it to you.



**Example 3**

Anne works for an automotive parts distributor and visits Switzerland to source new products. On a given day, the bank selling rate of the Swiss franc compared to the Canadian dollar is 1.0501 and the buying rate is 1.0213.

- How many Swiss francs would Anne receive for \$400.00 CAD?
- If Anne sold them back to the bank, how much would she receive?
- What would her net loss be?

**SOLUTION**

- The bank will sell Swiss francs to Anne, so use the selling rate. 1 Swiss franc is worth \$1.0501 CAD.

$$\frac{1 \text{ SFr}}{\$1.0501} = \frac{x}{\$400.00}$$

$$\frac{1}{1.0501} = \frac{x}{400.00}$$

Omit the units.

$$(400.00 \times \cancel{1.0501}) \times \frac{1}{\cancel{1.0501}} = \frac{x}{\cancel{400.00}} \times (1.0501 \times \cancel{400.00})$$

Multiply both sides of the equation by the product of the denominators. Simplify.

$$400.00 = 1.0501x$$

$$\frac{400.00}{1.0501} = x$$

Divide both sides by 1.0501 to isolate  $x$ .

$$380.92 = x$$

Anne would receive 380.92 Swiss francs.

**ALTERNATIVE SOLUTION**

- 1 Swiss franc is worth \$1.0501 CAD.

\$1.00 is therefore worth  $\frac{1}{1.0501}$  Swiss francs. Multiply this by 400 to calculate what \$400.00 CAD is worth.

$$400.00 \times \frac{1}{1.0501} = 380.92 \text{ Swiss francs}$$

- b) The bank buys the Swiss francs back at a rate of 1.0213 Swiss francs per \$1.00 CAD.

$$\frac{1 \text{ SFr}}{\$1.0213} = \frac{380.92 \text{ SFr}}{x}$$

$$\frac{1}{1.0213} = \frac{380.92}{x}$$

Omit the units.

$$(1.0213 \times x) \times \frac{1}{1.0213} = \frac{380.92}{x} \times (x \times 1.0213)$$

Multiply both sides of the equation by the product of the denominators.

$$x = 380.92 \times 1.0213$$

Simplify.

$$x = 389.03$$

Anne would receive \$389.03 CAD.

### ALTERNATIVE SOLUTION

- b) 1 Swiss franc is worth \$1.0213 CAD.

Multiply 380.92 Swiss francs by 1.0213 to find the value in Canadian dollars.

$$380.92 \times 1.0213 = \$389.03 \text{ CAD}$$

- c) Anne's net loss would be \$400.00 minus what she received back.

$$\$400.00 - \$389.03 = \$10.97$$

Anne would lose \$10.97 in the transaction.

Unit rates often work best for exchanging currency.

When customers exchange money at a bank or other institution, the bank will usually only deal with paper money, not coins.

**BUILD YOUR SKILLS**

11. If the exchange rate of a country compared to the Canadian dollar is 0.00519, will you get more or less of their currency units when you exchange money?
12. Dianne works as a bank teller in Canmore, AB. A customer wishes to buy 250 British pounds at a rate of 1.5379 \$CAD. How many Canadian dollars would the British pounds cost?
13. If the selling rate of a euro (€) is 1.4768 and the buying rate is 1.4287, how much would you lose if you exchanged \$1000.00 CAD for euros and then converted them back to \$CAD on the same day?

**PRACTISE YOUR NEW SKILLS**

1. Using the following information, calculate how much of the foreign currency you would get for \$500.00 CAD. Round to the nearest unit.
  - a) \$1.00 is worth 95.4911 Japanese yen    b) \$1.00 is worth 1.41046 Turkish lira
  
  
  
  
  
  
  
  
  
  
  - c) \$1.00 is worth 0.680228 euro                      d) \$1.00 is worth 6.43033 Chinese yuan
  
  
  
  
  
  
  
  
  
  
2. Damien is training to become a customer service representative at a credit union in Saskatoon, SK. Given the following exchange rates compared to the Canadian dollar, calculate how much foreign currency Damien would give to a customer who wished to convert \$500.00 CAD.
  - a) Mexican peso, 0.0818085                      b) Estonian kroon, 0.0939564
  
  
  
  
  
  
  
  
  
  
  - c) British pound, 1.3376                      d) South Korean won, 0.000922277
  
  
  
  
  
  
  
  
  
  
- e) Indian rupee, 0.0229526                      f) Russian ruble, 0.0352667

3. Using the rates from question #1, calculate the amount you would get in Canadian dollars if you sold the following.
- a) 8750 Japanese yen
  - b) 900 Turkish lira
  - c) 250 euros
  - d) 3000 Chinese yuan
4. Use the exchange rates from question #2. Calculate how many Canadian dollars you would get for each of the following.
- a) 6750 Mexican pesos
  - b) 145 British pounds
  - c) 15 000 Indian rupees
  - d) 750 Russian rubles
5. If the exchange rate is 0.1736 between the Norwegian krone and the Canadian dollar, what would the price be in Canadian dollars of an item that cost 275 kroner?









8. A furniture store in The Pas, Manitoba, advertises: “All weekend, no GST and no PST.” If GST and PST are usually 5% each, what is the actual saving as a percent on an item that costs \$24.97?
9. After prime planting season was over, a horticulturist sold lilac bushes for \$15.00. If the original price was \$39.00, what is the percentage markdown?
10. Non-profit agencies get a 12% reduction from Polly’s Printers. How much will they save on a printing job that regularly costs \$865.00?

11. James works for an industrial lighting company. He travels to Hong Kong to attend a trade show. James sees a fluorescent track lighting unit priced at 1295.31 Hong Kong dollars. What is the cost in Canadian dollars if \$1.00 CAD is worth 7.3181 Hong Kong dollars?

12. Marian travels to Spain to visit her mother and father.

a) \$1.00 CAD is worth €0.680228. If Marian converts \$450.00 CAD into euros, how many euros does she receive?

b) During her visit, Marian buys a leather purse for €125.00. What is the cost in Canadian dollars?

# Chapter 2

## Earning an Income



Many tradespeople such as electricians, welders, carpenters, and plumbers are employed by the construction industry. These men are installing rebar, the steel rods used to reinforce the walls and floors of concrete buildings.

## 2.1

### Wages and Salaries

#### REVIEW: WORKING WITH MIXED FRACTIONS

A proper fraction is a fraction where the numerator is smaller than the denominator, for example,  $\frac{2}{3}$  and  $\frac{8}{12}$ .

An improper fraction is one in which the numerator is greater than or equal to the denominator, for example,  $\frac{3}{2}$  and  $\frac{12}{8}$ . Improper fractions can be changed to mixed numerals.

A mixed numeral is a number represented as a whole number and a fraction, for example,  $2\frac{3}{4}$  and  $12\frac{5}{8}$ . In most cases, the fraction is simplified to its lowest terms.

**Example 1**

Change the improper fraction to a mixed numeral, expressed in its simplest form.

$$\frac{188}{12}$$

**SOLUTION**

To change an improper fraction to a mixed numeral, divide the numerator by the denominator and write the remainder as a fraction of the **divisor**.

$$188 \div 12 = 15, \text{ remainder } 8$$

When 188 is divided by 12, the **quotient** is 15 and the remainder is 8. The mixed numeral is  $15\frac{8}{12}$ . However, the fraction  $\frac{8}{12}$  can be further simplified.

$$\frac{8}{12} = \frac{8 \div 4}{12 \div 4}$$

$$\frac{8 \div 4}{12 \div 4} = \frac{2}{3}$$

$$\frac{8}{12} = \frac{2}{3}$$

The simplified mixed numeral is written as  $15\frac{2}{3}$ .

**ALTERNATIVE SOLUTION**

First simplify the improper fraction, then divide the numerator by the denominator.

$$\frac{188}{12} = \frac{188 \div 4}{12 \div 4} \quad \text{Simplify.}$$

$$\frac{188 \div 4}{12 \div 4} = \frac{47}{3}$$

$$\frac{188}{12} = \frac{47}{3}$$

$$47 \div 3 = 15, \text{ remainder } 2 \quad \text{Divide.}$$

The quotient is 15 and the remainder is 2, so the mixed numeral is  $15\frac{2}{3}$ .

**divisor:** in a division operation, the number by which another number is divided; in  $a \div b = c$ ,  $b$  is the divisor

**quotient:** the result of a division; in  $a \div b = c$ ,  $c$  is the quotient

**BUILD YOUR SKILLS**

1. Change the improper fractions to mixed numerals.

a)  $\frac{29}{7}$

b)  $\frac{493}{9}$

c)  $\frac{1005}{29}$

d)  $\frac{45}{6}$

e)  $\frac{398}{16}$

f)  $\frac{1000}{15}$

**Example 2**

Change the mixed numeral  $2\frac{3}{4}$  to an improper fraction.

**SOLUTION**

The mixed numeral can be broken up as follows:

$$2\frac{3}{4} = 2 + \frac{3}{4}$$

Change 2 to a fraction whose denominator is 4.

$$\frac{2}{1} = \frac{2 \times 4}{1 \times 4}$$

$$\frac{2 \times 4}{1 \times 4} = \frac{8}{4}$$

$$\frac{2}{1} = \frac{8}{4}$$

Now substitute this improper fraction into the expression above.

$$2\frac{3}{4} = 2 + \frac{3}{4}$$

$$2 + \frac{3}{4} = \frac{8}{4} + \frac{3}{4}$$

$$\frac{8}{4} + \frac{3}{4} = \frac{8+3}{4}$$

$$2\frac{3}{4} = \frac{11}{4}$$

**BUILD YOUR SKILLS**

2. Change the mixed numerals to improper fractions.

a)  $5\frac{6}{11}$

b)  $4\frac{7}{9}$

c)  $15\frac{8}{17}$

d)  $7\frac{5}{8}$

e)  $12\frac{4}{5}$

f)  $10\frac{7}{12}$

**NEW SKILLS: WORKING WITH INCOME**

A salary, a wage, or an income is the amount of money you receive for work you do. In some jobs, pay is calculated by the hour, while other jobs offer an annual income (paid weekly, biweekly, or monthly).

**Gross pay** is the amount you make before **deductions**. Deductions will be discussed in section 2.4.

For more details, see page 54 of *MathWorks 10*.

**Example 3**

Marcus works as an electrician and earns \$24.68/h. If it takes him 15 hours for one job, how much will he earn?

**SOLUTION**

Multiply his hourly wage by the number of hours he works.

$$\frac{\$24.68}{1 \text{ hour}} \times 15 \text{ hours} = \$370.20$$

He will earn \$370.20 on the job.

**gross pay:** the total amount of money earned before deductions; also called gross earnings or gross income

**deduction:** money taken off your paycheque to pay taxes, union fees, and for other benefits and programs

**BUILD YOUR SKILLS**

3. Martha works as a window dresser in her hometown of Victoria, BC. She charges \$16.72/h and it takes her 5 hours to finish the window at a local department store. How much will her gross pay be for the job?
4. Ben works as a carpenter for \$20.87/h. How much will he earn in a 40-hour work week?
5. Harpreet works in the trucking business. He charges \$35.75/h to haul materials for a local contractor. Last week he worked the following hours:
- 6 hours on Monday
  - 8 hours on Tuesday
  - 8 hours on Wednesday
  - 12 hours on Thursday

What was his gross income for the week?

**Example 4**

Last week, Chi worked 34 hours cutting lawns. His gross income was \$329.12. What was his hourly wage?

**SOLUTION**

Divide his gross income by the number of hours he works to calculate his wage per hour.

$$\frac{\$329.12}{34 \text{ hours}} = \frac{\$9.68}{1 \text{ hour}}$$

Chi earns \$9.68/h.

**BUILD YOUR SKILLS**

6. Last year, Liliana earned \$45 183.36 working in a Grande Prairie hair salon.

a) What was her average monthly income?

b) What was her average weekly income?



7. If Janny works a 40-hour work week as a receiving clerk in the Powell River Hospital and earns \$552.88 per week, what is her hourly wage?
8. Emile is a flag person and earned \$321.25 last week. If he worked 32.5 hours, what was his hourly salary?

**Example 5**

Antonio is a cashier in a store that sells Caribbean products, such as ginger syrup, *ackee* (a type of fruit), and *dasheen* (also known as taro, a root vegetable). His time card for one week is shown below.

Time Card: Antonio					
Day	Morning		Afternoon		Total Hours
	IN	OUT	IN	OUT	
Monday	9:00	11:45	12:45	3:00	
Tuesday	8:45	10:45	2:00	5:30	
Wednesday	9:00	12:00	1:00	4:00	
Thursday	9:30	12:00	1:15	3:45	
Friday	9:00	11:30	12:15	3:15	

- a) How many hours did he work?
- b) If he earns \$15.85 per hour, how much did he earn that week?

**SOLUTION**

- a) On Monday, Antonio worked  $2\frac{3}{4}$  hours in the morning and  $2\frac{1}{4}$  hours in the afternoon for a total of 5 hours.

On Tuesday, he worked 2 hours in the morning and  $3\frac{1}{2}$  hours in the afternoon for a total of  $5\frac{1}{2}$  hours.

On Wednesday, he worked 3 hours in the morning and 3 hours in the afternoon for a total of 6 hours.

On Thursday, he worked  $2\frac{1}{2}$  hours in the morning and  $2\frac{1}{2}$  hours in the afternoon for a total of 5 hours.

On Friday, he worked  $2\frac{1}{2}$  hours in the morning and 3 hours in the afternoon for a total of  $5\frac{1}{2}$  hours.

Add these amounts together.

$$5 + 5\frac{1}{2} + 6 + 5 + 5\frac{1}{2} = 27$$

Antonio worked 27 hours.

- b) Multiply the number of hours he worked by his hourly wage.

$$27 \times \$15.85 = \$430.70$$

Antonio earned \$430.70 that week.

**BUILD YOUR SKILLS**

9. Monty works after school at a gas station in Swift Current, SK. He earns \$9.45/h. How much would he earn if the time card below represents his work week?

Time Card: Monty			
Day	IN	OUT	Total Hours
Monday	3:30	6:45	
Tuesday			
Wednesday	5:00	9:30	
Thursday	5:00	9:30	
Friday	3:30	7:00	

Hae-rin often works a split shift, where her work day is split into two time blocks.

10. Hae-rin works as a part-time warehouse technician. She gets paid \$12.76/h and keeps her own time card. How much did she earn during the week?

Time Card: Hae-rin					
Day	Morning		Afternoon		Total Hours
	IN	OUT	IN	OUT	
Monday	7:45	9:00	5:00	7:45	
Tuesday			4:00	8:00	
Wednesday	9:00	11:00			
Thursday	9:00	11:00	3:00	5:00	
Friday			3:00	6:00	
Saturday	9:00	12:00			

## NEW SKILLS: WORKING WITH OVERTIME PAY

Many full-time jobs have a 40-hour work week, but others may have different regular hours. If you work more than the regular number of hours, it is classified as overtime and you will earn overtime pay for those extra hours. Overtime is often paid at “time and a half”—that is, 1.5 times your regular wage—but can be any other agreed-upon amount.

### Example 6

Marcel works for a construction company and earns \$15.82/h for a  $37\frac{1}{2}$ -hour work week. He is paid time and a half for any time that he works in excess of  $37\frac{1}{2}$  hours. If he works  $42\frac{1}{4}$  hours during one week, how much will he earn?

#### SOLUTION

Calculate Marcel’s overtime wage. It is time and a half, which means 1.5 times his regular wage.

$$1.5 \times \$15.82 = \$23.73$$

His overtime salary is \$23.73/h.

Calculate how many hours of overtime he worked by subtracting  $37\frac{1}{2}$  from  $42\frac{1}{4}$ . (Hint: Change these values to decimals to make subtracting easier.)

$$42.25 - 37.5 = 4.75$$

He worked 4.75 h overtime.

Find his total income by calculating his regular income and then his overtime income. Add the two amounts together.

Regular income:

$$37.5 \times \$15.82 = \$593.25$$

Overtime income:

$$4.75 \times \$23.73 = \$112.72$$

Total income:

$$\$593.25 + \$112.72 = \$705.97$$

Marcel earned \$705.97 during the week.

**BUILD YOUR SKILLS**

11. Pete works in road construction as a grader operator. His regular work week is 40 hours. During the busy season, he often has to work overtime. For overtime hours worked Monday to Friday, he earns time and a half. If he has to work on Saturday, he earns double time and a half. How much will Pete make if he works 45.25 hours during the week and 5.75 hours on Saturday? His regular salary is \$15.77/h.
  
12. Ingrid works as a medical receptionist at a rate of \$11.82/h. She regularly works 35 hours per week, but her clinic wants to increase her work week to 42 h. She agrees to do this if they will pay her overtime, at time and a half, for the extra hours. If they agree to pay this amount, what will her weekly pay be?
  
13. Nathalie works as a playground supervisor for 8 weeks during the summer at a rate of \$15.27/h for a 40-hour week. If she averages 3 hours of overtime each week, paid at time and a half, how much will she earn during the summer?

**PRACTISE YOUR NEW SKILLS**

1. What is your daily income if you earn \$10.75/h as a camp counsellor and you work 10 hours per day?
  
  
  
  
  
  
  
  
  
  
2. Lauren worked as an assistant at the National Métis Youth Conference. Her job was to provide support to people giving workshops. Lauren worked for  $7\frac{1}{2}$  hours at a rate of \$12.36/h. How much did she make?
  
  
  
  
  
  
  
  
  
  
3. Juanita has been offered a job that pays \$497.35 for a 35-hour work week. A second company offers her a job at \$16.75/h, but will only guarantee 30 hours per week. Which job would you advise Juanita to take?

4. Rita's annual income at her part-time job walking dogs is \$6758.00. Assuming she works the same amount of time each week, what is her weekly salary?

5. Abdul's time card is below. If his hourly wage is \$9.05, how much did he earn during the week?

Time Card: Abdul					
Day	Morning		Afternoon		Total Hours
	IN	OUT	IN	OUT	
Monday	9:05	12:15	1:20	5:00	
Tuesday	9:02	12:13	1:12	4:25	
Wednesday	8:58	12:14	1:05	4:19	
Thursday	9:02	12:12	12:58	4:14	
Friday	8:45	12:35	1:05	4:15	

6. Tandor has begun a job as an animal trainer in the movie industry. His starting wage is \$10.53/h for 30 hours per week. If he works more than 30 hours, he is paid 1.25 times his regular salary. How much will he earn if he works 35 hours in one week?

## Alternative Ways to Earn Money

# 2.2

### NEW SKILLS: WORKING WITH INCOME OPTIONS

Not all working people earn wages or a salary. There are other ways to earn income, including piecework, commission, salary plus commission, and contract work.

For more information, see page 64 of *MathWorks 10*.

#### Example 1

Greg works as a tree planter during the summer and he earns his income through piecework. He is paid \$2.50 for each seedling he plants. If he plants 45 seedlings in a day, how much will he earn?

#### SOLUTION

Multiply \$2.50 by 45.

$$\$2.50 \times 45 = \$112.50$$

He will earn \$112.50 that day.

#### BUILD YOUR SKILLS

1. Thomasina knits sweaters and sells them in her craft shop. She has been hired to knit sweaters for a team of 4 curlers and their spare. If she charges \$75.50 for a large sweater and \$69.75 for a medium sweater (because they require different amounts of wool), how much will she earn if she knits 3 large and 2 medium sweaters?



2. Patricia works in the garment industry. She is paid \$1.50 for each hem and \$2.25 for each waistband. How much does she earn by hemming 12 dresses and attaching 15 waistbands?
  
  
  
  
  
  
  
  
  
  
3. Jack cleans windows for extra income. He charges \$3.00 for a main floor window and \$5.00 for a second-storey window. How much will he earn if he cleans the windows on a house that has 7 main floor windows and 6 second-storey windows?

---

**Example 2**

Mary works as a flower arranger. She is paid \$143.75 for making 25 identical flower arrangements for a wedding. How much was she paid per arrangement?

**SOLUTION**

Find the unit rate. The easiest way to calculate this is to divide \$143.75 by 25.

$$\$143.75 \div 25 = \$5.75$$

She is paid \$5.75 per arrangement.



**Example 3**

Ming works in a store that sells classic Chinese furniture such as roundback armchairs and corner-leg stone stools. Ming works on commission at a rate of 6.5% of his gross sales. If he sold \$9865.00 worth of furniture last week, how much commission did he earn?

**SOLUTION**

Multiply his sales by his commission rate (expressed as a decimal).

$$\$9865.00 \times 0.065 = \$641.23$$

His commission was \$641.23.

**BUILD YOUR SKILLS**

- Peter works in a sporting goods store and earns 12% commission on his sales. How much does he make on a bicycle that sells for \$785.95?
- When selling a home, a real estate agent makes 5% commission on the first \$250 000.00 of the home's selling price and 2% on any amount over that. How much will Sue make if she sells a house worth \$375 900.00?

9. David earns a salary of \$375.00 per week plus 5% commission on his sales. If he sold \$6521.00 of goods, how much did he make?

**Example 4**

Olaf earned \$416.03 commission on his sales of \$9245.00. What was his rate of commission?

**SOLUTION**

You need to find what percent \$416.03 is of \$9245.00. Use proportional reasoning.

$$\begin{aligned}\frac{\$416.03}{\$9245.00} &= \frac{x}{100} \\ 100 \times \frac{\$416.03}{\$9245.00} &= \frac{x}{100} \times 100 \\ 100 \times \frac{\$416.03}{\$9245.00} &= x \\ 4.5 &\approx x\end{aligned}$$

His rate of commission was about 4.5%.

**ALTERNATIVE SOLUTION**

Divide Olaf's commission by his sales to find the rate of his commission as a decimal. Then multiply this by 100 to convert to a percentage.

$$\begin{aligned}\$416.03 \div \$9245.00 &\approx 0.045 \\ 0.045 \times 100 &= 4.5\end{aligned}$$

His rate of commission was 4.5%.

**BUILD YOUR SKILLS**

10. If Freddi earns \$6.86 on a \$95.95 sale, what was his rate of commission?
11. What is the rate of commission if you make \$592.00 on sales of \$12 589.00?
12. Don operates a small craft store in which he sells other people's crafts. He takes a 45% commission from the sales of all crafts. If he earned \$958.00 commission last week, how much did he sell?

**Example 5**

Gurpreet is figuring out what he should charge for repairing the steps on a client's house. The cost of materials will be \$785.96, and he will have to hire 2 workers for 8 hours each at a rate of \$12.85/h. He wants to earn at least \$450.00 for himself. What should he charge the client in the contract?

**SOLUTION**

Calculate all of Gurpreet's costs.

Cost of materials: \$785.96

Cost of labour:

$$2 \text{ people} \times 8 \text{ hours} \times \frac{\$12.85}{1 \text{ hour}} = \$205.60$$

Gurpreet's income: \$450.00

Add all of these costs to find the total cost of completing the repairs.

$$\$785.96 + \$205.60 + \$450.00 = \$1441.56$$

Gurpreet should charge \$1441.56.

Gurpreet would probably round this number. He might charge \$1450.00.

**BUILD YOUR SKILLS**

13. Marcel is bidding on a contract to lay concrete on a patio. He decides to calculate his actual costs and then add 20% profit for himself. He needs 3 cubic yards of concrete at \$100.00 per cubic yard delivered. He needs to pay 2 employees \$12.45/h each for 4 hours to do the job. What should he charge the client?
14. Tien has three employees working for her. Each employee is paid the minimum wage in BC, \$8.00/h, for an 8-hour day. They are also paid a commission of 12% on all sales they make. If the three employees made sales of \$785.96, \$452.87, and \$616.42, how much must Tien pay in total for the day?
15. Kate works at the front desk for a sheet metal company that recently completed 5 contracts. The contracts were worth \$5600.00, \$2800.00, \$7450.00, \$1900.00, and \$8900.00. Materials, salaries, and other expenses amounted to \$23 750.00. What was the percentage of the profits?

**PRACTISE YOUR NEW SKILLS**

1. A farmer pays his son \$8.25 for each bucket of wild blueberries he picks. He then sells them at a roadside stand for \$15.00 per bucket.
  - a) How much does his son earn if he picks 28 buckets of blueberries?
  
  
  
  
  
  
  
  
  
  
  - b) How much does the farmer earn?
  
  
  
  
  
  
  
  
  
  
2. A car company pays its salespeople 2% commission on the amount of their sales after cost. Joey sells a car for \$23 000.00 that cost the company \$15 000.00. How much did Joey make in commission?
  
  
  
  
  
  
  
  
  
  
3. Larissa earns a base salary of \$500.00 per week plus 4% commission on any sales. How much will she have to sell to earn \$750.00 in a week?



4. Paulette has been hired to make bridesmaids' dresses for a wedding. She knows that it will take her approximately 9.5 hours to sew each dress and that the material for each dress costs \$120.00. Paulette decides to charge \$240.00 per dress. At this price, what is her hourly rate?
5. Jeff's bid on a contract was \$15 980.00. His costs would be \$12 250.00, plus he would have to pay a labourer for 36 hours at \$12.45/h.
- a) Jeff's potential client indicated that another contractor offered a bid that was 10% lower. Would Jeff be justified in lowering his contract price to the same amount? Why or why not?
- b) Jeff calculated that he will put 50 hours into the job. If he lowers the bid, what will his hourly income be?

**Additional Earnings****2.3****NEW SKILLS: WORKING WITH INCOME SUPPLEMENTS**

A bonus is an extra amount earned for a job well done or for exceeding expectations, and is paid in addition to regular pay and/or overtime pay. It may be a lump sum or a percentage of earnings. Danger pay, isolation pay, a shift premium, and tips are also paid in addition to regular pay.

For more information, see page 72 of *MathWorks 10*.

**Example 1**

Marika works during the summer as a supervisor of a children's program at the local community centre. She has a good reputation with the children and her employer wants her to come back next year. Marika earned \$3600.00 during the summer and her employer offers her a 15% signing bonus if she will sign up for next year. If Marika signs up, how much will she get as a signing bonus?

**SOLUTION**

Find 15% of Marika's wages.

$$0.15 \times \$3600.00 = \$540.00$$

She will make \$540.00 as a signing bonus.

**BUILD YOUR SKILLS**

1. Chester wants to clear out his used car sales lot in Surrey, BC. To do so, he offers his employees an incentive for each car they sell. They will receive bonuses in the following amounts:
  - \$50.00 for each car they sell for more than \$20 000.00
  - \$40.00 for each car they sell between \$15 000.00 and \$19 999.00
  - \$30.00 for each car they sell between \$10 000.00 and \$14 999.00
  - \$25.00 for each car they sell below \$10 000.00

Gerry sells cars worth \$14 895.00, \$19 998.00, \$15 675.00, \$7250.00, and \$15 229.00. What is his bonus pay?

2. Raymond receives isolation pay for working in Wabasca, AB. If his regular pay is \$2245.00/month, and he is offered a bonus of 12% or \$275.00/month, which should he take?
3. Darren works as a logging machine operator. His salary is \$24.80/h. Due to the dangerous nature of his job, he makes 38% more per hour than Sean, who is a forklift operator. How much do Darren and Sean each make in an 8-hour day?

**Example 2**

Conchita works as a bus driver for a transit company. Since busy times of the day require more drivers than midday, the company requires that some employees work split shifts. The bus company offers a 12% shift premium for the second shift to anyone that has a 4-hour break between the end of one shift and the beginning of the next.

If Conchita earns \$17.82/h, how much will she earn during the week?

Time Card: Conchita		
Day	Shift 1	Shift 2
Monday	6:15–11:00	3:30–6:45
Tuesday	6:15–10:15	3:30–7:15
Wednesday	12:00–4:00	6:00–9:00
Thursday	3:30–7:30	
Friday	8:00–11:00	2:00–4:45

**SOLUTION**

Determine the days on which Conchita will receive a shift premium.

Monday:  $4\frac{1}{2}$  hours – Premium

Tuesday:  $5\frac{1}{4}$  hours – Premium

Wednesday: 2 hours – No premium

Thursday: no break – No premium

Friday: 3 hours – No premium

Calculate the shift premium rate by find 112% of her regular wage (as a decimal, 1.12).

$$1.12 \times \$17.82 = \$19.96$$

Calculate the hours worked in each shift and the income per shift.

Time Card: Conchita		
Day	Shift 1	Shift 2
Monday	$4.75 \times \$17.82 = \$84.65$	$3.25 \times \$19.96 = \$64.87$
Tuesday	$4 \times \$17.82 = \$71.28$	$3.75 \times \$19.96 = \$74.85$
Wednesday	$4 \times \$17.82 = \$71.28$	$3 \times \$17.82 = \$53.46$
Thursday	$4 \times \$17.82 = \$71.28$	
Friday	$3 \times \$17.82 = \$53.46$	$2.75 \times \$17.82 = \$49.01$

Calculate total income by adding.

$$\$84.65 + 3(\$71.28) + 2(\$53.46) + \$64.87 + \$74.85 + \$49.01 = \$594.14$$

Conchita will earn \$594.14 during the week.

**ALTERNATIVE SOLUTION**

Determine the number of hours for which she earned regular pay.

Monday: 4.75 hours

Tuesday: 4 hours

Wednesday: 7 hours

Thursday: 4 hours

Friday: 5.75 hours

Total: 25.5 hours

Add up the number of hours for which she received a shift premium.

Monday: 3.25 hours

Tuesday: 3.75 hours

Total: 7 hours

Calculate her shift premium rate by finding 112% of her regular wage.

$$112 \div 100 = 1.12$$

$$1.12 \times \$17.82 = \$19.96$$

Calculate her regular income and her premium income, and then add the two.

Regular income:

$$25.5 \text{ hours} \times \frac{\$17.82}{\text{hour}} = \$454.41$$

Premium income:

$$7 \text{ hours} \times \frac{\$19.96}{\text{hour}} = \$139.72$$

$$\$454.41 + \$139.72 = \$594.13$$

Conchita will earn \$594.13 during the week.

This answer differs from the first solution by \$0.01, due to rounding in the first solution.

**BUILD YOUR SKILLS**

4. Regular hours at the computer repair shop where Denise works are 9:00 am to 5:00 pm, Monday to Friday. Her boss has offered a shift premium of \$1.75/hour to anyone who will work after 5:00 pm or on Saturday. Last week, Denise worked the following hours:

- Monday: 9:00 am–5:00 pm
- Tuesday: 2:00 pm–8:00 pm
- Wednesday: 2:00 pm–7:00 pm
- Thursday: 12:00 pm–8:00 pm
- Saturday: 9:00 am–3:00 pm

If her regular pay was \$15.25/h, how much did she earn last week?

5. Drivers for the Fast Delivery Parcel Company are offered a shift premium if they drive the night shift (after 8:00 pm) to deliver parcels by 9:00 the next morning. Baljeet's schedule last week was as follows:

- Monday: 12:00 pm–7:00 pm
- Tuesday: 9:00 am–5:00 pm
- Wednesday: 6:00 pm–12:00 am
- Thursday: 12:00 pm–8:00 pm
- Friday: 3:00 pm–9:00 pm

His regular pay is \$12.75/h, and the shift premium is \$7.00/h. How much did he make last week?

6. Chen is offered isolation pay of \$1250.00 for a job in northern Manitoba. Alternatively, he can have a bonus payment of 28% of his salary. If his salary is \$532.00/wk, which is the better option if it takes 10 weeks to complete the job?

### Example 3

Suzette works as a waitress in a local café in Selkirk, MB. Yesterday she made \$165.32 in tips. If this was 15% of the bills she collected, how much were the bills?

#### SOLUTION

Let  $x$  be the total of the bills. Use proportional reasoning.

$$\frac{15}{100} = \frac{165.32}{x}$$

$$100x \left( \frac{15}{100} \right) = \left( \frac{165.32}{x} \right) 100x \quad \begin{array}{l} \text{Multiply both sides by the product of} \\ \text{the denominators.} \end{array}$$

$$15x = 165.32 \times 100 \quad \text{Simplify.}$$

$$15x = 16\,532$$

$$\frac{15x}{15} = \frac{16\,532}{15} \quad \text{Divide both sides by 15 to isolate } x.$$

$$x = \$1102.13$$

Her orders totalled \$1102.13.

#### ALTERNATIVE SOLUTION

You know that \$165.32 equals 15% of the total orders. Use this to calculate 1% of the orders.

$$\$165.32 \div 15 \approx \$11.0213$$

Multiply this number by 100 to get 100% of the total orders.

$$11.0213 \times 100 = \$1102.13$$

Suzette's orders totalled \$1102.13.

**BUILD YOUR SKILLS**

7. Kirsten earns a base salary of \$8.20/h plus tips. On a typical day, she bills her customers \$950.00, and her tips average 15%. What is Kirsten's average daily income with tips for an 8-hour day?
8. Mandeep is at a restaurant in Prince Rupert, BC. He has decided that 15% is too much to leave for a waiter who did not provide good service. He left \$3.00 on a meal that cost \$24.75. What percentage tip did he leave?
9. Rosita earned \$408.65 working 35 hours at \$8.21/h plus tips. How much did she make in tips?

In most restaurants, 15% is the average expected tip amount. A quick way to estimate a 15% tip is to round off your bill, find 10% by moving the decimal one place to the left, and then add half of that number to itself.

For example, if the bill is \$68.89, round up to \$70.00.

10% is \$7.00.

Half of \$7.00 is \$3.50.

$\$7.00 + \$3.50 = \$10.50$

The total tip would be \$10.50. This is slightly more than 15% because you rounded up, so you may want to pay about \$79.00.





3. Restaurant sales totalled \$40 568.00 one month, and the average tip was 15%.
  - a) How much would each of the three waiters make in tips if they shared equally?
  
  
  
  
  
  
  
  
  
  
  - b) If they give 25% of their tips to the kitchen staff, how much will each waiter make?
  
  
  
  
  
  
  
  
  
  
4. Franco earns \$17.23/h, time and a half overtime, and a shift bonus of \$2.65 for split shifts. If he worked a total of 43.5 hours, 18 of which were split shifts, how much did he earn if a regular work week was 38.5 hours?
  
  
  
  
  
  
  
  
  
  
5. Horace works as a door-to-door salesman in rural Alberta and must use his own car. He is paid \$0.45/km for each kilometre he drives, plus 8% of sales. If he drove 2354 km and sold \$47 854.00 of merchandise, how much would his paycheque be?

## 2.4

## Deductions and Net Pay

## NEW SKILLS: WORKING WITH NET INCOME

**taxable income:**

income after before-tax deductions have been applied, on which federal and provincial taxes are paid

**net income:**

income after all taxes and other deductions have been applied; also called take-home pay

Deductions are amounts of money taken off your gross pay for income tax (federal and provincial or territorial), union dues, disability insurance, employment insurance (EI), pension plans (including the Canada Pension Plan or CPP), and health or other benefits. Income tax is paid on your **taxable income**.

Each paycheque should list your gross pay, all deductions, and your **net income**. At the end of the year, your employer will supply you with a T4 slip that you will use to prepare your income tax return.

For more details, see page 79 of *MathWorks 10*.

**Example 1**

John's group life insurance is 1.5% of his salary of \$450.00 every two weeks. How much does he pay for group life insurance?

**SOLUTION**

Change 1.5% to a decimal and multiply by his salary.

$$1.5 \div 100 = 0.015$$

$$0.015 \times \$450.00 = \$6.75$$

He pays \$6.75 for group life insurance per paycheque.

Some deductions are taxable, and some are not. For example, union dues and company pension plans are before-tax deductions, and so they are not subject to federal and provincial taxes.

**BUILD YOUR SKILLS**

1. If the federal tax rate is 15%, how much is deducted from your \$750.00 paycheque?
2. If your short-term disability insurance rate is 0.5%, what do you pay if your paycheque is \$300.00?
3. If your Canada Pension Plan (CPP) contribution rate is 4.95% and your salary is \$1578.00 every two weeks, what will be the CPP deduction?

Income tax rates vary with province or territory, salary, and family circumstances.

**Example 2**

Jaar had a gross income of \$785.00. His net income was \$625.42. What percentage of his gross pay were his deductions?

**SOLUTION**

Calculate the amount of the deductions by subtracting his net income from his gross income.

$$\$785.00 - \$625.42 = \$159.58$$

Calculate what percentage \$159.58 is of \$785.00.

$$159.58 \div 785.00 \approx 0.2033$$

$$0.2033 \times 100 = 20.33\%$$

His deductions are about 20.3% of his gross pay.

**BUILD YOUR SKILLS**

4. Samara's monthly taxable income was \$3276.54. If she paid \$757.24 in taxes, what percentage of her taxable income did she pay?

5. Patricia's before-tax deductions amounted to \$75.47 on a gross salary of \$700.00.

a) If she paid \$93.68 in federal tax, what is her tax rate?

b) If she paid \$36.85 in territorial tax, what is her tax rate?

6. Hans paid \$37.51 Employment Insurance (EI) on his taxable monthly income of \$2168.21. What is the EI rate?

**Example 3**

Alphonso has a gross income of \$852.00 per week. His before-tax deductions include union dues of 2.5% of his gross income and a company pension plan contribution of 3%. His federal tax rate is 16.2% and his provincial tax rate is 5.4%. He pays 4.95% to the CPP and 1.8% for EI. Calculate his net income.

**SOLUTION**

Calculate Alphonso's taxable income by subtracting his union dues and his company pension from his gross income.

First, calculate the amount of his union dues and company pension.

Union dues:

$$2.5 \div 100 = 0.025$$

$$0.025 \times \$852.00 = \$21.30$$

Company pension:

$$3 \div 100 = 0.03$$

$$0.03 \times \$852.00 = \$25.56$$

Next, subtract these amounts from his gross income to find his taxable income.

$$\$852.00 - (\$21.30 + \$25.56) = \$805.14$$

Calculate the amount of taxes, CPP, and EI using his taxable income.

Federal tax:

$$16.2 \div 100 = 0.162$$

$$0.162 \times \$805.14 = \$130.43$$

Provincial tax:

$$5.4 \div 100 = 0.054$$

$$0.054 \times \$805.14 = \$43.48$$

CPP:

$$4.95 \div 100 = 0.0495$$

$$0.0495 \times \$805.14 = \$39.85$$

EI:

$$1.8 \div 100 = 0.018$$

$$0.018 \times \$805.14 = \$14.99$$

Alphonso's net income will be his taxable income minus these deductions.

$$\$805.14 - \$130.42 - \$43.48 - \$14.49 = \$576.89$$

Alphonso's net income will be \$576.89.

### BUILD YOUR SKILLS

- Randy works at two jobs. In one job, he earns \$325.00/week, and has deductions of \$56.67 federal tax, \$13.12 provincial tax, \$16.09 CPP, and \$4.14 EI. At his other job, he earns \$567.00/week and pays \$79.42 federal tax, \$16.82 provincial tax, and \$18.12 CPP. What is his net income?
- As a part-time college instructor, Kathy teaches an introductory course on Mexican history. She has a biweekly gross income of \$3654.75. Her before-tax deductions include a short-term disability premium of 0.5%, union dues of 3.1%, and a pension amount of 4%. If she pays federal tax at a rate of 18.5%, provincial tax at a rate of 6.2%, CPP at 4.95%, and EI at 2.2%, what is her net income?



9. Consider the following pay statement.

Employee Name: Hank			
Company:	Pay Begin Date: 06/01/2010	Net Pay: ???	
	Pay End Date: 06/15/2010	Cheque Date: 06/15/2010	
<b>General</b>		<b>Taxes Data</b>	
Employee ID:	Job Title:	Description	Federal
Address:	Pay Rate: \$575.00 Annual: \$29 900.00	Claim Code	1
<b>Hours and Earnings</b>		<b>Taxes</b>	
	Current		
<b>Description</b>	<b>Rate</b>	<b>Gross Earnings</b>	
Regular	\$575.00/wk	\$575.00	
		<b>Description</b>	<b>Current</b>
		Federal	\$48.01
		Provincial	\$21.64
		CPP	\$25.13
		EI	\$9.95
		<b>Total</b>	<b>\$104.73</b>

- a) What is Hank's gross weekly income?
- b) What is his net income?
- c) What percent of his taxable income did he pay in federal taxes?

**PRACTISE YOUR NEW SKILLS**

1. Juliana has an annual salary of \$45 785.00.
  - a) How much does she pay in union dues if the rate is 2.4%?
  
  
  
  
  
  
  
  
  
  
  - b) How much does she pay in CPP if the rate is 4.95% and her taxable income is \$44 686.16?
  
  
  
  
  
  
  
  
  
  
2. Mario had \$685.74 deducted in federal tax. If his taxable income was \$2981.52, what was his tax rate?
  
  
  
  
  
  
  
  
  
  
3. What will be your net pay if you have deductions of \$105.30 federal tax, \$23.76 provincial tax, \$48.61 CPP, and \$14.12 EI from your paycheque of \$982.00?







12. Padma has been offered isolation pay of \$125.00/week to work as a park ranger in northern Alberta.

a) How much will she make in a 40-hour work week if she is normally paid \$21.52/h?

b) Adding in the isolation pay, what is her hourly rate?

# Chapter 3

## Length, Area, and Volume



*Kristi Hansen is a Red Seal plumber. Calculating the capacity of water lines, determining the length of pipe needed for drainage systems, and accurately predicting the volume of hot water a building's system will use are some of her tasks.*

### 3.1

## Systems of Measurement

### REVIEW: WORKING WITH PERIMETER

**perimeter:** the sum of the lengths of all the sides of a polygon

In this section, you will calculate the **perimeter** of different shapes.

A square is a quadrilateral with 4 equal sides, so the perimeter can be found by the following formula:

$$P = 4 \times (\text{side length})$$

The perimeter of a rectangle with length  $\ell$  and width  $w$  can be found by the following formula:

$$P = 2\ell + 2w$$

$$P = 2(\ell + w)$$

**Example 1**

What is the perimeter of this figure?

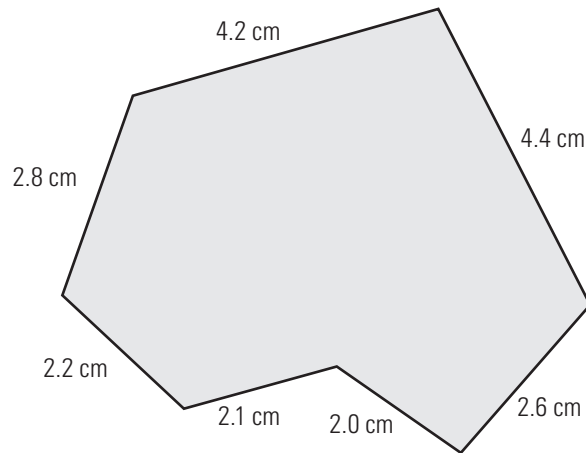
**SOLUTION**

This figure is a heptagon, which means it has 7 sides. Its perimeter,  $P$ , is the sum of the lengths of all 7 sides.

$$P = 2.8 + 4.2 + 4.4 + 2.6 + 2.0 + 2.1 + 2.2$$

$$P = 20.3 \text{ cm}$$

The perimeter is 20.3 cm.

When the units of measurement are all the same, you can ignore them during calculations. Remember to add the units in at the end.

To make sure that you don't miss any sides when calculating the perimeter of a figure, start at one vertex and work your way around the figure.



**BUILD YOUR SKILLS**

A small square symbol in the corner of a diagram means that it is a right angle.

1. Calculate the perimeters of the following diagrams.

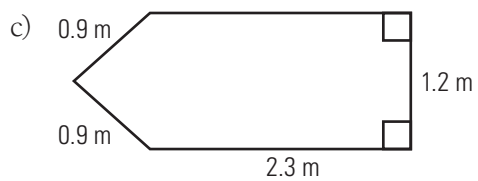
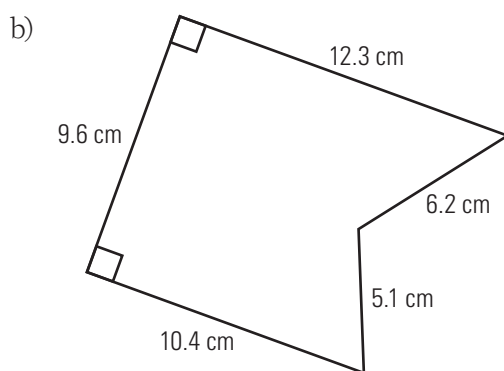
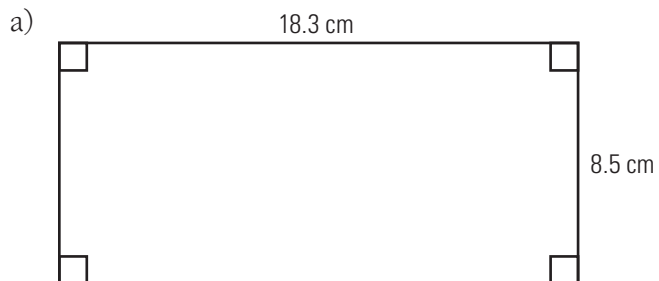

2. Darma is edging a tablecloth with lace. The tablecloth is 210 cm by 180 cm. How much lace does she need?

3. Garry installs a wire fence around a rectangular pasture. The pasture measures 15 m by 25 m, and he uses three rows of barbed wire. How much wire did he use?

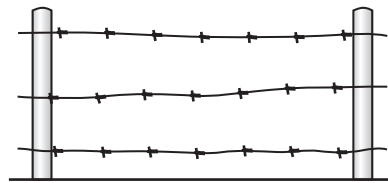

4. Chantal is building a fence around her swimming pool. The pool is 25 ft long and 12 ft wide, and she wants a 6-ft wide rectangular walkway around the entire pool. How much fencing will she need?

**Example 2**

The sides of the flower garden shown below are 4 m long. Each end is a semi-circle with a diameter of 2 m. What is the perimeter of the flower garden?

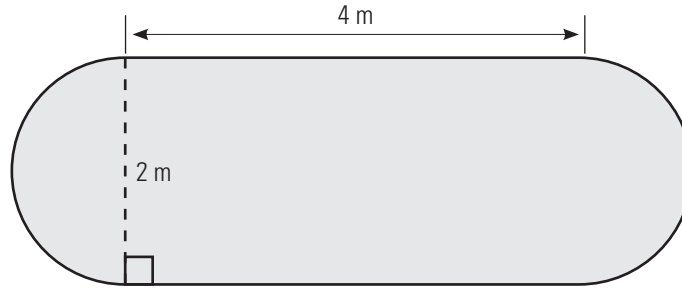
**SOLUTION**

Break this problem down into two parts, a circle and a rectangle.

If you add the two end sections together, they form a circle. You can use the formula for the **circumference** to find the perimeter:

$$C = \pi d \text{ or } 2\pi r$$

$C$  is the circumference,  $r$  is the radius,  $d$  is the diameter, and  $\pi$  is a constant. In this example, the diameter is 2 m.

Find the circumference of the ends of the flower garden by using this formula.

$$C = \pi d$$

$$C = \pi(2)$$

$$C \approx 6.28$$

Add the lengths of the two straight parts to the circumference of the circle to calculate the perimeter.

$$P \approx 6.28 + 4 + 4$$

$$P \approx 14.28$$

The perimeter of the flower garden is about 14.28 m.

**circumference:** the measure of the perimeter of a circle

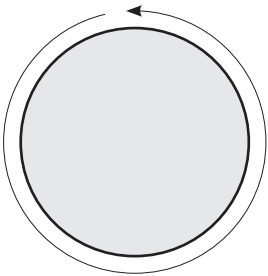

**BUILD YOUR SKILLS**

5. What is the circumference of a circular fountain if its radius is 5.3 m?

6. Johnny wants to put Christmas lights along the edge and peak of his roof. How many metres of lights will he need?

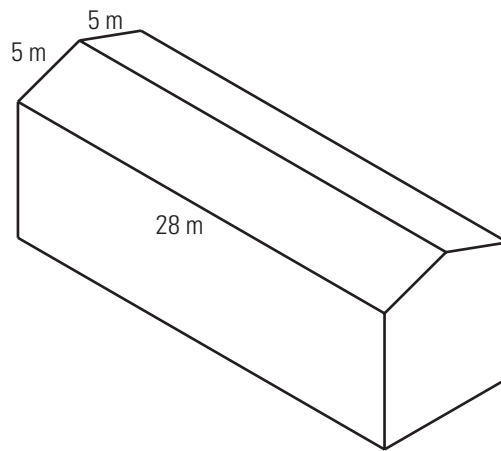

7. Hershey uses coloured wire to make a model of the Olympic symbol (5 interlocking circles). If each circle has a radius of 35 cm, how much wire does he need for the rings?

## NEW SKILLS: WORKING WITH SYSTEMS OF MEASUREMENT

### Système International

**(SI):** the modern version of the metric system; uses the metre as the basic unit of length

**imperial system:** the system most commonly used in the United States; the standard unit of measurement for length is the foot

Although there are other systems of measurement, the two most common are the **Système International (SI)** and the **imperial system**. In Canada, the official system of measurement is the SI. Because of Canada's close proximity to the United States, you should be familiar with both systems. Both are used in certain contexts.

Below are listed some common imperial units of length and their relationships.

$$12 \text{ inches (in or ") = 1 foot (ft or ')}$$

$$36 \text{ inches = 1 yard (yd)}$$

$$3 \text{ feet = 1 yard}$$

$$5280 \text{ feet = 1 mile (mi)}$$

$$1760 \text{ yards = 1 mile}$$

For more details, see page 94 of *MathWorks 10*.

### Example 3

Wilhelmina, a seamstress, is sewing bridesmaids' dresses. She orders the fabric from the United States, where fabric is measured in yards. Each dress requires  $3\frac{3}{4}$  yards of silk,  $1\frac{1}{2}$  yards of lace fabric, and  $7\frac{1}{4}$  yards of trim. How much of each type of material does Wilhelmina need to make 5 dresses?

### SOLUTION

Multiply each amount by 5.

$$\text{silk} = 3\frac{3}{4} \times 5$$

$$\text{silk} = \frac{15}{4} \times 5 \quad \text{Convert to an improper fraction and multiply.}$$

$$\text{silk} = \frac{75}{4}$$

$$\text{silk} = 18\frac{3}{4} \text{ yd} \quad \text{Convert to a mixed fraction.}$$

$$\text{lace fabric} = 1\frac{1}{2} \times 5$$

$$\text{lace fabric} = \frac{3}{2} \times 5 \quad \text{Convert to an improper fraction and multiply.}$$

If you look at a ruler marked in imperial units, you will notice that it is usually divided into halves, quarters, eighths, and sixteenths, whereas the SI system uses tenths.

$$\text{lace fabric} = \frac{15}{2}$$

$$\text{lace fabric} = 7\frac{1}{2} \text{ yd} \quad \text{Convert to a mixed fraction.}$$

$$\text{trim} = 7\frac{1}{4} \times 5$$

$$\text{trim} = \frac{29}{4} \times 5 \quad \text{Convert to an improper fraction and multiply.}$$

$$\text{trim} = \frac{145}{4}$$

$$\text{trim} = 36\frac{1}{4} \text{ yd} \quad \text{Convert to a mixed fraction.}$$

Since fabric can be bought in partial yards, Wilhelmina will need to purchase  $18\frac{3}{4}$  yd of silk,  $7\frac{1}{2}$  yd of lace fabric, and  $36\frac{1}{4}$  yd of trim.

#### ALTERNATIVE SOLUTION

Convert each mixed fraction to a decimal, and then multiply by 5.

$$\text{silk} = 3\frac{3}{4}$$

$$\text{silk} = 3.75$$

$$\text{silk} = 3.75 \times 5$$

$$\text{silk} = 18.75$$

$$\text{lace fabric} = 1\frac{1}{2}$$

$$\text{lace fabric} = 1.5$$

$$\text{lace fabric} = 1.5 \times 5$$

$$\text{lace fabric} = 7.5$$

$$\text{trim} = 7\frac{1}{4}$$

$$\text{trim} = 7.25$$

$$\text{trim} = 7.25 \times 5$$

$$\text{trim} = 36.25$$

Since fabric can be bought in partial yards, Wilhelmina will need to purchase 18.75 yd of silk, 7.5 yd of lace fabric, and 36.25 yd of trim.

**BUILD YOUR SKILLS**

A 2 by 4 is not exactly 2" by 4". The name comes from the dimensions of the lumber before it is dried; when the lumber dries, it shrinks and then is replaned to make it a standard size. A 2 by 4 is actually  $1\frac{1}{2}$ " by  $3\frac{1}{2}$ ". Lumber and other building supplies are usually sold using imperial units.

8. Bernard is buying some lumber to finish a project. He needs 3 pieces of 2 by 4 that are each  $4\frac{1}{2}$  feet long, and 10 pieces of 2 by 2 that are each  $5\frac{1}{4}$  feet long. How much of each does he need in total?
9. Benjie is replacing some plumbing pipes. He needs 3 pieces of copper pipe: one piece is 2 feet long, one is 5 feet 7 inches long, and one is 4 feet long. How much copper pipe does he need if he loses 1 inch when he cuts the pipe and he can only buy it in even numbers of feet?
10. If each board in a fence is 6 inches wide, how many of them will José need to fence a playground that is 60 feet wide by 125 feet long?

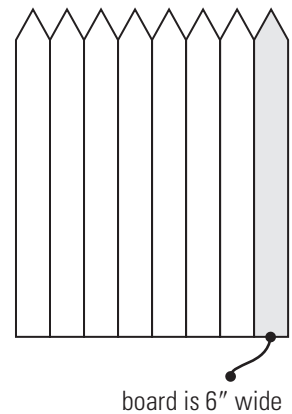

**Example 4**

Fatima is trying to calculate how much baseboard she will need for the room shown below.

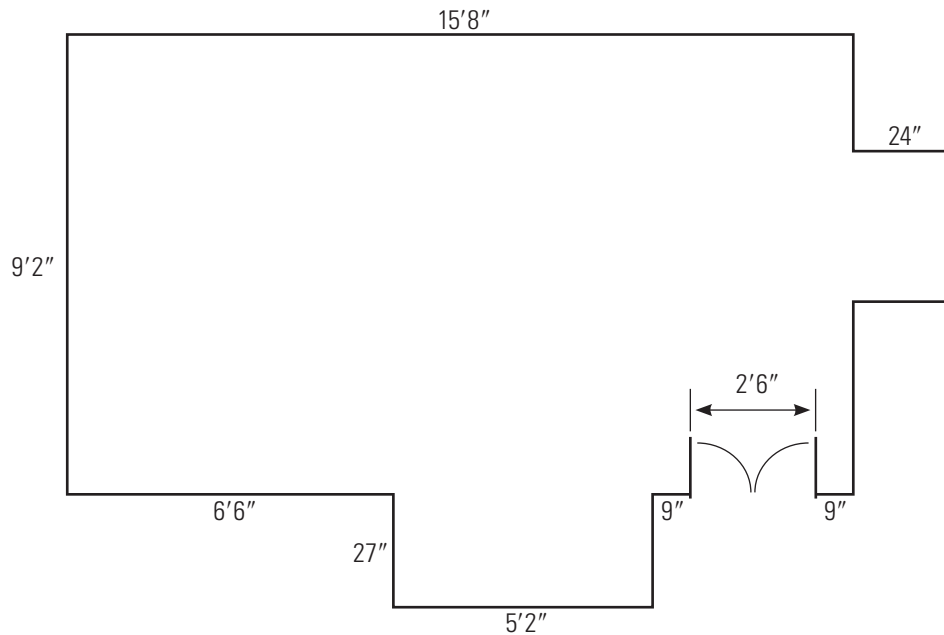

What is the minimum amount of baseboard she will need?

**SOLUTION**

Find the perimeter of the room. Since there is a door, no baseboard will be needed there. Measurements are given in feet and/or inches.

To find the perimeter of the room, start at any one point, such as the edge of the door, and work your way around the room.

$$P = 9'' + 27'' + 5'2'' + 27'' + 6'6'' + 9'2'' + 15'8'' + 9'2'' + 24'' + 24'' + 9''$$

Add feet to feet and inches to inches to get 44' 140''.

Convert 140 inches to feet by dividing by 12 (because 12 inches equals 1 foot).

$$\frac{140}{12} = 11 \text{ remainder } 8, \text{ or } 11'8''$$

Add this to the measure in feet.

$$44' + 11'8'' = 55'8''$$

Therefore, she needs 55'8'' of baseboard.

Where did the second 9'2'' come from?



**ALTERNATIVE SOLUTION**

Combine the lengths of the smaller wall segments to simplify the calculation, and subtract the width of the door.

$$P = 2(15'8'') + 2(9'2'') + 2(27'') + 2(24'') - 2'6''$$

$$P = 30'16'' + 18'4'' + 54'' + 48'' - 2'6''$$

$$P = 46'116''$$

Convert 116 inches to feet.

$$\frac{116}{12} = 9, \text{ remainder } 8, \text{ or } 9'8''$$

Add this to the measure in feet.

$$46' + 9'8'' = 55'8''$$

Therefore, she needs 55' 8" of baseboard.

**BUILD YOUR SKILLS**

11. A pet shop stores 5 pet cages that are 2'8" wide, 3 cages that are 4'6" wide, and 2 cages that are 1'8" wide. Can these cages fit side by side along a wall that is 30' long?
  
  
  
  
  
  
  
  
  
  
12. A circular garden is 6'4" in diameter. To plant a geranium approximately every foot along the circumference, how many geraniums are needed?

13. The height of a basement ceiling is  $7'2''$ . A  $6''$ -deep heating pipe runs across the middle. To enclose it, there must be a 1-inch space between the pipe and the drywall. Will Craig, who is  $6'6''$  tall, be able to walk under the finished pipe?

**PRACTISE YOUR NEW SKILLS**

1. Convert the following measurements.

a) 42 inches to feet

b) 16 inches to feet and inches

c) 96 inches to yards

d) 5 miles to yards



## Converting Measurements

# 3.2

### REVIEW: WORKING WITH VARIABLES WITHIN FORMULAS

In this section, you will practise substituting known values into formulas.

In this chapter, you will need to use the following formulas.

$$A = \ell w \quad \text{Area of a rectangle, where } \ell \text{ is the length and } w \text{ is the width.}$$

$$A = \pi r^2 \quad \text{Area of a circle, where } r \text{ is the radius and } \pi \text{ is the constant, pi.}$$

$$A = \frac{1}{2}bh \quad \text{Area of a triangle, where } b \text{ is the length of the base and } h \text{ is the height.}$$

$$A = \pi rs \quad \text{Area of the surface of a cone, where } r \text{ is the radius and } s \text{ is the slant height.}$$

$$C = 2\pi r \quad \text{Circumference of a circle, where } r \text{ is the radius.}$$

### Example 1

*Sumo* is a traditional Japanese martial art. The area of a circular sumo ring, or *dohyo*, is  $16.26 \text{ m}^2$ . What is the radius of the ring?

#### SOLUTION

Use the formula for finding the area of a circle. You are given the area of the circle, so substitute it into the formula and solve for the unknown value,  $r$ .

$$A = \pi r^2$$

$$16.26 = \pi r^2$$

$$\frac{16.26}{\pi} = \frac{\cancel{\pi}r^2}{\cancel{\pi}} \quad \text{Divide both sides by } \pi \text{ to isolate } r^2.$$

$$\sqrt{\frac{16.26}{\pi}} = r$$

$$2.28 \approx r$$

The radius of a sumo ring is 2.28 m.

**BUILD YOUR SKILLS**

1. Ina is laying turf in a yard measuring 38 ft by 20 ft. What is the yard's area in square feet?
2. A store advertises a circular rug as being  $4.9 \text{ m}^2$ . Travis wants a rug to fit a rectangular space that is 2.6 m by 2.6 m. Will this rug fit?
3. You are designing a rectangular label for canned food. The can is 5 cm high, with a diameter of 9 cm. To plan your design, calculate the label's length. (The length is equal to the circle's circumference.)

**NEW SKILLS: WORKING WITH DIFFERENT SYSTEMS OF MEASUREMENT**

The official system of measurement in Canada is the SI, but the United States uses imperial units. If you are buying products from the United States or are doing business with a US company, you will need to convert between the two systems of measurement.

Below are some common relationships between SI and imperial units of length.

$$1 \text{ inch} \approx 2.54 \text{ centimetres}$$

$$1 \text{ foot} \approx 0.3 \text{ metres}$$

$$1 \text{ yard} \approx 0.9 \text{ metres}$$

$$1 \text{ mile} \approx 1.6 \text{ kilometres}$$

For more details, see page 106 of *MathWorks 10*.

**Example 2**

Mary is delivering a load of goods from Vancouver, BC, to Seattle, WA, then in Seattle, she is picking up another load to deliver to Albuquerque, NM. The distance from Vancouver to Seattle is 220 km and the distance from Seattle to Albuquerque is 1456 mi. The odometer in Mary's truck records distance in kilometres.

- What is the total distance she will travel, in kilometres?
- If her odometer read 154 987 km when she left Seattle, what did it read when she left Vancouver?
- What will her odometer read when she reaches Albuquerque?

**SOLUTION**

- Find the distance in kilometres from Seattle to Albuquerque.

$$1 \text{ mi} \approx 1.6 \text{ km}$$

$$1456 \text{ mi} \approx 1456 \times 1.6$$

$$1456 \text{ mi} \approx 2330 \text{ km}$$

The distance from Seattle to Albuquerque is 2330 km.

Add this to the distance from Vancouver to Seattle to find the total distance.

$$220 \text{ km} + 2330 \text{ km} = 2550 \text{ km}$$

Her trip will be about 2550 km.

- Subtract the distance she travelled from the odometer reading.

$$154\,987 - 220 = 154\,767$$

Her odometer read 154 767 when she left Vancouver

- Add the distance from Seattle to Albuquerque to the odometer reading.

$$154\,987 + 2330 = 157\,317$$

Her odometer should read about 157 317 when she reaches Albuquerque.







**Example 3**

Rebecca is planning to install sod in her backyard, which is 18.2 m by 9.8 m. If sod costs  $\$0.28/\text{ft}^2$ , how much will it cost to sod the backyard?

**SOLUTION**

Change the measurements of the backyard to feet, and then find the area.

$$0.3 \text{ m} = 1 \text{ ft}$$

$$18.2 \text{ m} = \frac{18.2}{0.3} \text{ ft}$$

$$\frac{18.2}{0.3} \approx 60.7 \text{ ft}$$

Her yard is approximately 61 ft long.

Similarly, change 9.8 m (980 cm) to feet.

$$1 \text{ m} = \frac{1}{0.3} \text{ ft}$$

$$9.8 \text{ m} = \frac{9.8}{0.3} \text{ ft}$$

$$\frac{9.8}{0.3} \approx 32.7 \text{ ft}$$

Her yard is approximately 33 ft wide.

Calculate the area of her backyard. The area of a rectangle is calculated by multiplying the length by the width.

$$A = \ell w$$

$$A = 61 \times 33$$

$$A = 2013 \text{ ft}^2$$

She will need approximately 2013 square feet of sod at  $\$0.28/\text{ft}^2$ .

$$2013 \times \$0.28 = \$563.64$$

It will cost about  $\$563.64$  to sod her backyard.

**BUILD YOUR SKILLS**

7. You could have solved Example 3 by determining the cost of the sod per square metre. Answer the question using this method. Is your answer the same? Why or why not?
8. Kuldeep has been hired to lay terracotta tiles on a floor that measures 4.2 m by 3.8 m. The tiles are 9" by 9" and come in boxes of 12.
- a) How many boxes must he buy? (He cannot buy a partial box.)
- b) If the tiles cost \$18.95 per box, how much will the tiles cost in total?

9. Toula calculates the cost of cementing the bottom and sides of a circular pond. When all costs are considered, the job will cost \$175.85 per square metre of finished area. If the pond has a radius of 3 feet and a depth of 2 feet, how much will she charge for the job?





6. Ari, a gardener, estimates the cost of seeding a 150 m by 210 m area with grass seed. He needs 3 pounds of seed per 100 000 square feet. How many pounds of seed will Ari need?
7. A room measures 12'8" by 10'9". Carpeting costs \$45.98/m<sup>2</sup>. A customer will have to purchase 10% more carpeting than floor area due to waste and he cannot purchase partial square metres. What is the minimum cost of the carpeting?

## 3.3

## Surface Area

## NEW SKILLS: WORKING WITH SURFACE AREA

**surface area:** the total area of all the faces, or surfaces, of a three-dimensional object; measured in square units

**net:** a two-dimensional pattern used to construct three-dimensional shapes

**Surface area** is the area that would be covered by a three-dimensional (3-D) object if you could lay it out flat. A **net** is a diagram of a 3-D object seen as a flat surface.

If you know how to find the area of 2-D shapes, you can find the surface area of 3-D objects by breaking them down to their component surfaces and adding the areas together.

For more details, see page 115 of *MathWorks 10*.

## Example 1

Akiko has been hired to paint the exterior of a storage bin. If the bin is a rectangular prism that measures 2.3 yards by 4.4 yards by 2.8 yards, what is the surface area of the bin?

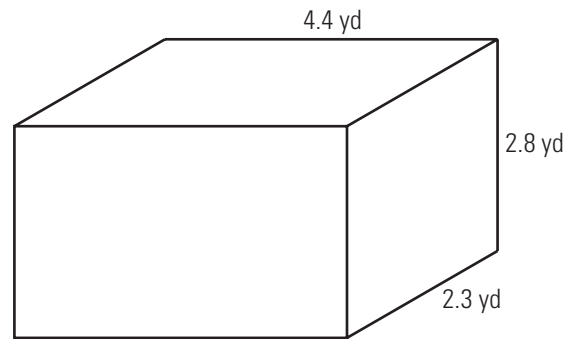

## SOLUTION

Sketch a net of the bin.

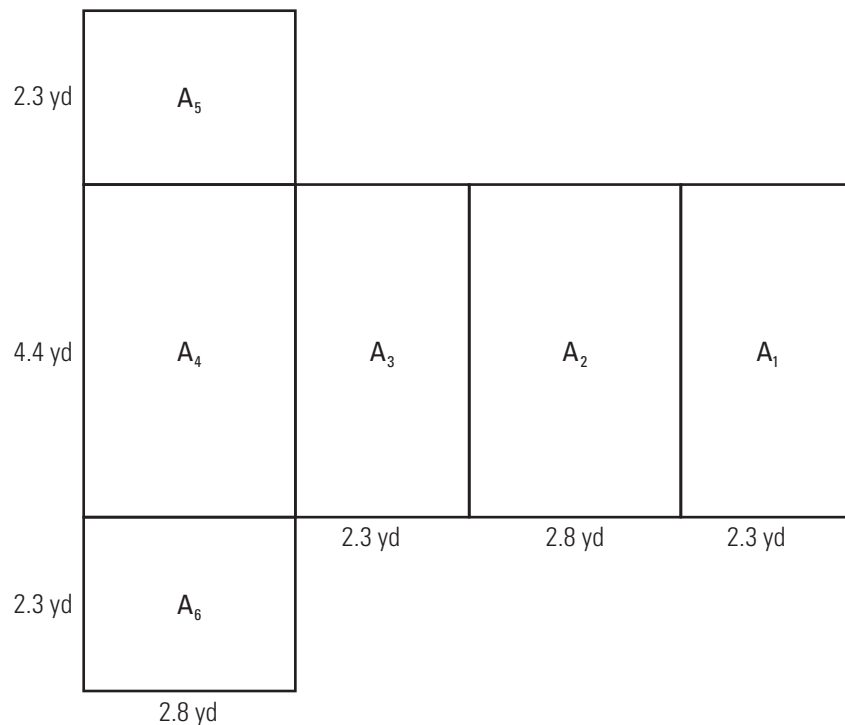

Calculate the area of each of the rectangles and add together to find the surface area (SA).

$$A_1 = \ell w$$

$$A_1 = 4.4 \times 2.3$$

$$A_1 = 10.12 \text{ yd}^2$$

The area of  $A_3$  is the same as  $A_1$ .

$$A_2 = \ell w$$

$$A_2 = 4.4 \times 2.8$$

$$A_2 = 12.32 \text{ yd}^2$$

The area of  $A_4$  is the same as  $A_2$ .

$$A_5 = \ell w$$

$$A_5 = 2.3 \times 2.8$$

$$A_5 = 6.44 \text{ yd}^2$$

The area of  $A_6$  is the same as  $A_5$ .

Total surface area:

$$SA = A_1 + A_2 + A_3 + A_4 + A_5 + A_6$$

$$SA = 10.12 + 12.32 + 10.12 + 12.32 + 6.44 + 6.44$$

$$SA = 57.76 \text{ yd}^2$$

The bin has a surface area of 57.76 yd<sup>2</sup>.



**ALTERNATIVE SOLUTION**

Many people prefer to measure the different surfaces of the object.

There are:

2 rectangles that are 4.4 yd by 2.8 yd (front and back)

2 rectangles that are 4.4 yd by 2.3 yd (top and bottom)

2 rectangles that are 2.3 yd by 2.8 yd (ends)

Find the area of each rectangle and then add.

$$A_{1+3} = 2 \times 4.4 \text{ yd} \times 2.3 \text{ yd}$$

$$A_{1+3} = 20.24 \text{ yd}^2$$

$$A_{2+4} = 2 \times 4.4 \text{ yd} \times 2.8 \text{ yd}$$

$$A_{2+4} = 20.24 \text{ yd}^2$$

$$A_{5+6} = 2 \times 2.3 \text{ yd} \times 2.8 \text{ yd}$$

$$A_{5+6} = 12.88 \text{ yd}^2$$

$$SA = A_{1+3} + A_{2+4} + A_{5+6}$$

$$SA = 20.24 \text{ yd}^2 + 20.24 \text{ yd}^2 + 12.88 \text{ yd}^2$$

$$SA = 57.76 \text{ yd}^2$$

The bin has a surface area of 57.76 yd<sup>2</sup>.



**Example 2**

A canning factory wants to use as little metal as possible to make its cans. It considers two can sizes that each hold about the same amount. One is 4.5 inches tall with a radius of 4.2 inches and another is 9.6 inches tall with a radius of 2.8 inches.

Which can should they use? Why?

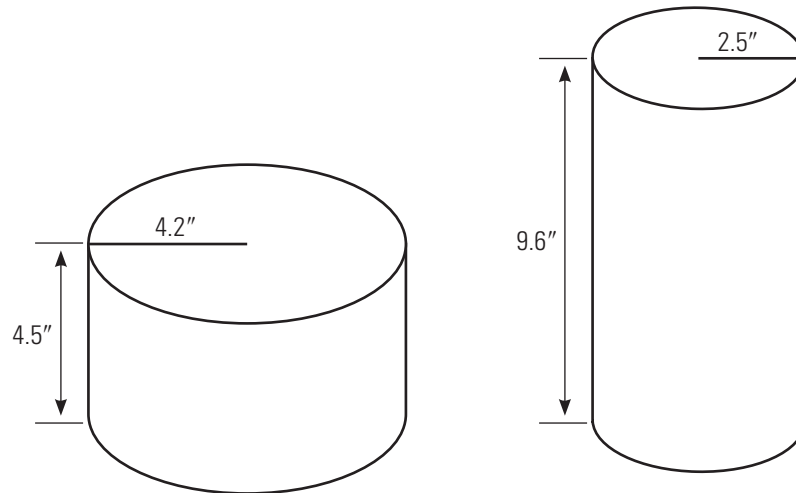
**SOLUTION**

To find out which can uses the least amount of metal, calculate the surface area of each can.

The top and bottom of the cans are circles. The area of a circle can be found by the following formula:

$$A = \pi r^2$$

If the side of the can is rolled out flat, it will form a rectangle, where the width is the height of the can and the length is the circumference of the circle.

**Can #1**

Top and bottom:

$$A = 2\pi r^2$$

$$A = 2\pi(4.2)^2$$

$$A \approx 110.8 \text{ in}^2$$

Side:

$$A = 2\pi rh$$

$$A = 2\pi(4.2)(4.5)$$

$$A \approx 118.7 \text{ in}^2$$

$$SA = A_{\text{top + bottom}} + A_{\text{side}}$$

$$SA \approx 110.8 + 118.7$$

$$SA \approx 229.5 \text{ in}^2$$

**Can #2**

Top and bottom:

$$A = 2\pi r^2$$

$$A = 2\pi(2.8)^2$$

$$A \approx 49.2 \text{ in}^2$$

Side:

$$A = 2\pi rh$$

$$A = 2\pi(2.8)(9.6)$$

$$A \approx 168.8 \text{ in}^2$$

$$SA = A_{\text{top + bottom}} + A_{\text{side}}$$

$$SA \approx 49.2 + 168.8$$

$$SA \approx 218 \text{ in}^2$$

Considering surface area, they should use the second can because it uses less material.

**BUILD YOUR SKILLS**

4. A cylindrical shipping tube is 48 inches tall and 6 inches in diameter.
- a) What is its surface area in square inches?

- b) What is its surface area in square feet?
5. Sanjiv designs a cylindrical box to hold 4 tennis balls stacked one on top of the other. If a tennis ball is approximately  $3\frac{1}{4}$  inches in diameter, what is the surface area of the box? (Ignore the thickness of the material.)
6. Jennifer must make a conical funnel out of sheet metal. If the funnel is 9 inches tall, has a slant height of 10.7 inches, and has a radius of 5.8 inches at the top, what is the surface area of the sheet metal in square feet?

**Example 3**

Harry has to paint the walls and ceiling of a room that is 12 ft long, 10 ft wide, and  $8\frac{1}{2}$  ft high. There is a 6 ft by 4 ft window, a  $2\frac{1}{2}$  ft by 7 ft doorway, and a mirrored closet door that is 6 ft by 7 ft. What surface area must he paint?

**SOLUTION**

Find the total area of the four walls and the ceiling and subtract the areas of the window and doors.

Area of ceiling:

$$A_1 = 12 \text{ ft} \times 10 \text{ ft}$$

$$A_1 = 120 \text{ ft}^2$$

Area of long walls:

$$A_2 = 12 \text{ ft} \times 8\frac{1}{2} \text{ ft} \times 2$$

$$A_2 = 204 \text{ ft}^2$$

Area of shorter walls:

$$A_3 = 10 \text{ ft} \times 8\frac{1}{2} \text{ ft} \times 2$$

$$A_3 = 170 \text{ ft}^2$$

Area of walls and ceiling, including openings:

$$A_4 = A_1 + A_2 + A_3$$

$$A_4 = 120 \text{ ft}^2 + 204 \text{ ft}^2 + 170 \text{ ft}^2$$

$$A_4 = 494 \text{ ft}^2$$

Calculate the areas of the window, door, and closet that will not be painted.

Area of window:

$$A_5 = 6 \text{ ft} \times 4 \text{ ft}$$

$$A_5 = 24 \text{ ft}^2$$

Area of door:

$$A_6 = 2\frac{1}{2} \text{ ft} \times 7 \text{ ft}$$

$$A_6 = 17\frac{1}{2} \text{ ft}^2$$

Area of closet door:

$$A_7 = 6 \text{ ft} \times 7 \text{ ft}$$

$$A_7 = 42 \text{ ft}^2$$

Total area that does not need painting:

$$A_8 = A_5 + A_6 + A_7$$

$$A_8 = 24 \text{ ft}^2 + 17 \frac{1}{2} \text{ ft}^2 + 42 \text{ ft}^2$$

$$A_8 = 83 \frac{1}{2} \text{ ft}^2$$

Total area to be painted:

$$A_{total} = A_4 - A_8$$

$$A_{total} = 494 \text{ ft}^2 - 83 \frac{1}{2} \text{ ft}^2$$

$$A_{total} = 410 \frac{1}{2} \text{ ft}^2$$

The total area to be painted is  $410 \frac{1}{2} \text{ ft}^2$ .

### BUILD YOUR SKILLS

7. Geneviève plans to apply two coats of paint to the walls of her garden shed. The shed is 8 feet long by 6 feet wide by 7 feet tall. If there are 3 windows that are 2 feet by 18 inches each, what will be the total area she paints?

8. A metal cylindrical canister is 1'3" long and has a diameter of 4 inches. What is the total surface area of the cylinder?
9. Jerg is finishing the sides and bottom of a hot tub. The hot tub is 6'11" long, 5'6" wide, and 3' deep. It has a bench going all the way around the inside that is 16" high and 15" wide that will not be finished. How much finishing material will Jerg need?



**Example 4**

The wood that Terrance wants to use to make a shelving unit costs \$6.49/ft<sup>2</sup>. How much will it cost him (assuming no wastage) to make a shelving unit that is 4 ft wide by 12 inches deep by 5 ft tall if there are 4 shelves (plus the top and bottom)?

**SOLUTION**

Sketch the unit.

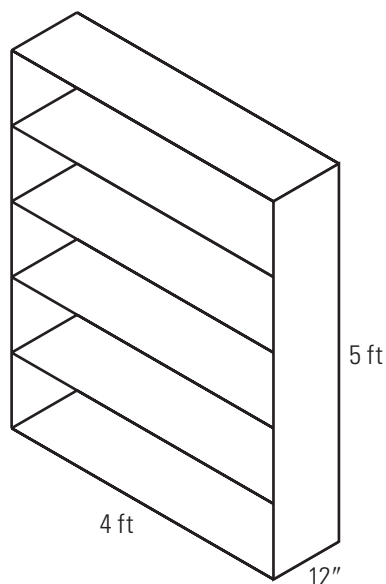

There will be 6 pieces (shelves) that are 12" (or 1') by 4'.

There will be 2 pieces (ends) that are 1' by 5'.

There will be 1 piece (back) that is 4' by 5'.

Find the areas of each piece and add.

$$A_1 = 6 \times 1 \text{ ft} \times 4 \text{ ft}$$

$$A_1 = 24 \text{ ft}^2$$

$$A_2 = 2 \times 1 \text{ ft} \times 5 \text{ ft}$$

$$A_2 = 10 \text{ ft}^2$$

$$A_3 = 1 \times 4 \text{ ft} \times 5 \text{ ft}$$

$$A_3 = 20 \text{ ft}^2$$

$$\text{Total area} = 24 \text{ ft}^2 + 10 \text{ ft}^2 + 20 \text{ ft}^2$$

$$\text{Total area} = 54 \text{ ft}^2$$

Cost:

$$\$6.49 \times 54 = \$350.46$$

The total cost of the wood will be \$350.46.

**BUILD YOUR SKILLS**

10. Randi is installing flooring in her den. The room is 12 feet by 19 feet. A fireplace that is 6 feet wide juts out 2 feet into the room. Also, there are 2 built-in bookcases, each 1 foot deep and 3 feet wide. She needs to order 12% more flooring than required because of wastage and cutting. How much will it cost if the wood costs \$5.25/ft<sup>2</sup>?
11. Sheet metal costs \$54.25/yd<sup>2</sup>. How much will it cost Hamish to cover a conical roof if it has a radius of 2.2 yards and a slant height of 3.5 yards?

12. Ted is wallpapering his bedroom. The room is 10 ft long by 8 ft wide by  $9\frac{1}{2}$  ft tall. There is a door measuring 3 ft by 7 ft and a window measuring 3 ft by 4 ft. Each double roll covers approximately  $56 \text{ ft}^2$  and costs \$29.95. How much will the wallpaper cost?



3. Stan is deciding between patio tiles that are 39 cm by 39 cm and tiles that are 18 cm by 27 cm. His patio is 3 m by 2.5 m. Considering area only, how many of each type of tile would he need?
4. A chocolate bar is in the shape of a triangular prism. The box is  $8\frac{1}{2}$  inches long and the ends are equilateral triangles with sides measuring  $1\frac{3}{4}$  inches. What is the surface area of the box? (Hint: You need to find the height of the triangle. Use the following formula,  $A = \frac{1}{2}bh$ )



## 3.4

## Volume

## NEW SKILLS: WORKING WITH VOLUME

**volume:** the amount of space an object occupies

The **volume** of a solid is a measure of how much space it occupies. Volume is measured in cubic units.

The volume of a prism is calculated using the following formula.

$$V = A_{\text{base}} \times h$$

Volume is the product of the area of the base times the height of the object.

For more details, see page 124 of *MathWorks 10*.

## Example 1

Alfred has a bulk container that holds 2000 cubic inches of dog biscuits. He plans to sell the biscuits in small boxes that measure 5" by 8" by 6". How many boxes will he need to sell all the dog biscuits?

## SOLUTION

Find the volume of the small box.

$$V = \ell wh$$

$$V = 5'' \times 8'' \times 6''$$

$$V = 240 \text{ cu in}$$

Divide 2000 by 240.

$$2000 \div 240 = 8.3$$

Round up, so that all of the biscuits fit in boxes. Alfred would need 9 small boxes.





**Example 2**

Paulino runs a landscaping business. He needs to cover an area that is 10.8 m by 9.5 m with 10 cm of topsoil. How much will it cost if the soil costs \$18.75/yd<sup>3</sup>, and soil is available in multiples of  $\frac{1}{2}$  yd<sup>3</sup>?

Remember:

$$10 \text{ cm} = 0.1 \text{ m}$$

**SOLUTION**

Find the volume of topsoil needed.

$$V = \ell wh$$

$$V = 10.8 \text{ m} \times 9.5 \text{ m} \times 0.1 \text{ m}$$

$$V = 10.26 \text{ m}^3$$

Calculate how many yards are in 1 metre.

$$1 \text{ cm} = \frac{1}{2.54} \text{ in}$$

$$100 \text{ cm} = \frac{100}{2.54} \text{ in}$$

$$100 \text{ cm} = 39.37 \text{ in}$$

$$1 \text{ m} = 39.37 \text{ in}$$

$$1 \text{ in} = \frac{1}{36} \text{ yd}$$

$$39.37 \text{ in} = \frac{39.37}{36} \text{ yd}$$

$$1 \text{ m} \approx 1.09 \text{ yd}$$

Calculate how many cubic yards are in a cubic metre by cubing both sides.

$$1 \text{ m}^3 = 1.09 \text{ yd}^3$$

$$1 \text{ m}^3 \approx 1.3 \text{ yd}^3$$

Since he needs 10.26 cubic metres, change cubic metres to cubic yards.

$$10.26 \text{ m}^3 = 10.26 \text{ m}^3 \times \frac{1.3 \text{ yd}^3}{1 \text{ m}^3}$$

$$10.26 \text{ m}^3 \approx 13.3 \text{ yd}^3$$

He needs  $13.3 \text{ yd}^3$ , but Paulino will have to round up to the nearest  $\frac{1}{2} \text{ yd}^3$ , to  $13.5 \text{ yd}^3$ . Since each cubic yard costs \$18.75, multiply the number of cubic yards by the cost per cubic yard.

$$13.5 \times \$18.75 = \$253.13$$

The topsoil will cost \$253.13.

### ALTERNATIVE SOLUTION

Begin by changing the measurements to yards.

Using the calculations above, 1 m is approximately 1.09 yd.

$$10.8 \text{ m} = 10.8 \times 1.09 \text{ yd}$$

$$10.8 \text{ m} \approx 11.8 \text{ yd}$$

$$9.5 \text{ m} = 9.5 \times 1.09 \text{ yd}$$

$$9.5 \text{ m} \approx 10.4 \text{ yd}$$

$$0.1 \text{ m} = 0.1 \times 1.09 \text{ yd}$$

$$0.1 \text{ m} \approx 0.1 \text{ yd}$$

Find the volume in cubic yards.

$$V = \ell wh$$

$$V = 11.8 \times 10.4 \times 0.1$$

$$V = 12.3 \text{ yd}^3$$

Paulino will need to round up to the nearest 0.5 cubic yard, so he will need  $12.5 \text{ yd}^3$ .

Find the cost by multiplying the number of cubic yards by the cost per cubic yard.

$$12.5 \times \$18.75 = \$234.38$$

It will cost approximately \$234.38 for the topsoil. This answer is different from the first answer because you round at a different point in the calculation.



## NEW SKILLS: WORKING WITH CAPACITY

The **capacity** of a container is the amount it can hold. Capacity is the volume of a container. Capacity is often used with liquid measures.

In the SI, the basic unit of capacity is the litre. A litre is one one-thousandth of a cubic metre, or 1000 cubic centimetres.

In imperial units, capacity is measured in gallons.

$$4 \text{ quarts} = 1 \text{ gallon}$$

$$2 \text{ pints} = 1 \text{ quart}$$

$$2 \text{ cups} = 1 \text{ pint}$$

However, the gallon has two different sizes:

- The British gallon is approximately 4.5 litres and 1 pint is 20 fluid ounces.
- The American (US) gallon is approximately 3.8 litres and 1 pint is 16 fluid ounces.

In measuring liquids for recipes, the US system is often used.

$$1 \text{ teaspoon (tsp)} = 5 \text{ millilitres (mL)}$$

$$1 \text{ tablespoon (tbsp)} = 15 \text{ mL}$$

$$1 \text{ cup} = 250 \text{ mL}$$

For more information, see page 124 of *MathWorks 10*.

**capacity:** the maximum amount that a container can hold

1 cup is actually 237 mL, but in cooking it is rounded to 250 mL for easier measuring.

**Example 3**

Paula is opening a French bakery and wants to make authentic French recipes. All the recipes are given in metric units, but she has imperial measuring devices. The crème brûlée recipe requires 500 mL of cream and 1.25 mL of vanilla.

- How much cream will she need, in cups?
- How much vanilla will she need, in teaspoons?
- How much cream will she need, in fluid ounces?

**SOLUTION**

- a) Convert 500 mL to cups.

$$1 \text{ cup} = 250 \text{ mL}$$

$$500 \text{ mL} = 500 \text{ mL} \times \frac{1 \text{ cup}}{250 \text{ mL}}$$

$$500 \text{ mL} = 2 \text{ cups}$$

She will need 2 cups of cream.

- b) Convert 1.25 mL to teaspoons.

$$1 \text{ tsp} = 5 \text{ mL}$$

$$1.25 \text{ mL} = 1.25 \text{ mL} \times \frac{1 \text{ tsp}}{5 \text{ mL}}$$

$$1.25 \text{ mL} = 0.25 \text{ tsp or } \frac{1}{4} \text{ tsp}$$

She will need  $\frac{1}{4}$  tsp of vanilla.

- c) Convert 500 mL to fluid ounces.

$$500 \text{ mL} = 2 \text{ cups}$$

$$2 \text{ cups} = 1 \text{ pint}$$

$$1 \text{ pint} = 16 \text{ fl oz}$$

She will need 16 fl oz of cream.

**BUILD YOUR SKILLS**

7. Serina is travelling through the US and her car's gas tank has a capacity of 55 litres.
- How much is this in American gallons?
  - If gas costs \$2.99/gal in Bellingham, WA, how much will it cost to fill her car (assuming that it is totally empty)?
  - Assuming she has the same car in London, England, where gas costs \$9.86/gal (converted from pounds), how much will it cost to fill her tank? (Remember that the British gallon is a different size.)
8. The box of Jakob's cube van has inside dimensions of 20 feet (length), 10 feet 8 inches (width), and 12 feet 6 inches (height). Calculate the volume of the interior.

9. Bev has two storage bins for grain. The first bin is 12 feet 8 inches by 8 feet 9 inches and is filled to a level height of 4 feet 6 inches. If she has to move the grain to a bin with a base measuring 9 feet by 9 feet, what will be the level height of the grain in the second bin?

**PRACTISE YOUR NEW SKILLS**

1. A storage container measures 6 feet by 3 feet by 4 feet.
  - a) What is the volume in cubic feet?
  
  
  
  
  
  
  
  
  
  
  - b) What is the volume in cubic yards?
  
  
  
  
  
  
  
  
  
  
2. A recipe calls for  $2\frac{3}{4}$  cups of milk. How much is this in mL?





6. The exterior of a concrete container will be 10 feet by 8 feet by 4 feet tall. The walls and the bottom are 6 inches thick. What will it cost to construct it if concrete is \$98.95/cubic yard?





4. Mario is laying tiles for the patio below and planting daffodils around the perimeter.

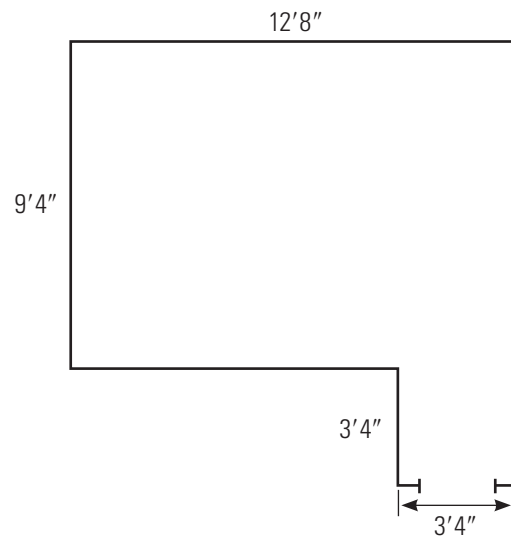

- a) Assuming he needs to buy 10% more than the area due to wastage, how many  $12''$  by  $12''$  tiles will he need?

- b) How many daffodils will he plant around the perimeter if there are no daffodils along the entrance and he plants them approximately 1 foot apart?

5. Louise needs to give the exterior of a cylindrical granary 2 coats of paint. If the granary is 10 feet tall and has a diameter of 14 feet, and paint covers approximately 375 square feet per gallon, how many gallons of paint will she need to buy? Assume that she can only buy full gallons, and will not be painting the roof.
6. Roberto is painting the exterior of a rectangular storage unit to protect it from rusting. If the unit is 7'6" wide, 9'8" long, and 8'2" tall, what is the surface area in square feet? Roberto will be painting the sides and the roof.



10. In the US, milk is commonly sold in jugs of 1 gal,  $\frac{1}{2}$  gal, 1 quart, and  $\frac{1}{2}$  pint. What are the equivalent sizes in millilitres?

11. A recipe for pumpkin cheesecake calls for a 5-US fl oz can of evaporated milk.

a) What is this in cups?

b) What is this in mL?

# Chapter 4

## Mass, Temperature, and Volume



To make good bread, the ingredients must be measured accurately and the dough stored and baked at the correct temperature. Cam McCaw, a Red Seal pastry chef, turns out hundreds of loaves of bread daily.

### Temperature Conversions

## 4.1

#### NEW SKILLS: WORKING WITH TEMPERATURE

If you travel to the United States, you will notice that a different temperature scale is used there. The US uses the Fahrenheit scale ( $^{\circ}\text{F}$ ) of the imperial system, while Canada uses the Celsius scale ( $^{\circ}\text{C}$ ) of the SI.

In the SI, water freezes at  $0^{\circ}\text{C}$  and boils at  $100^{\circ}\text{C}$ . In the imperial system, water freezes at  $32^{\circ}\text{F}$  and boils at  $212^{\circ}\text{F}$ . Since water freezes at  $0^{\circ}\text{C}$  and  $32^{\circ}\text{F}$ , the relationship between the two temperature systems can be calculated with the following formulas, where  $C$  represents degrees Celsius and  $F$  represents degrees Fahrenheit.

$$C = \frac{5}{9}(F - 32) \text{ or } F = \frac{9}{5}C + 32$$

For more details, see page 138 of *MathWorks 10*.

The Celsius scale used to be called the centigrade scale, and it is sometimes referred to this way.



When working with temperatures, convert them to the nearest tenth of a degree.

### Example 1

While visiting Florida, Kathy heard a local person say that it had been very cold overnight, as it was only  $42^\circ$ . At first, she thought this was not cold, but then Kathy realized the person meant degrees Fahrenheit. What was the temperature in degrees Celsius?

#### SOLUTION

Use the following formula, and substitute 42 for  $F$ .

$$C = \frac{5}{9}(F - 32)$$

$$C = \frac{5}{9}(42 - 32)$$

$$C = \frac{5}{9}(10)$$

$$C = \frac{50}{9}$$

$$C = \left(5\frac{5}{9}\right)^\circ$$

Convert this mixed numeral to a decimal.

$$5\frac{5}{9} = 5 + \frac{5}{9}$$

$$\frac{5}{9} = 5 \div 9$$

$$\frac{5}{9} \approx 0.6$$

$$5\frac{5}{9} \approx 5.6$$

The temperature is about  $5.6^\circ\text{C}$ , which would be very cold in Florida.



**Example 2**

Sverre was paving a road with heated tar during a hot summer day. He noted that the external temperature of the tar was  $48^{\circ}\text{C}$ . What was this in degrees Fahrenheit?

**SOLUTION**

Use the formula for converting degrees Fahrenheit to degrees Celsius, and substitute 48 for  $C$ .

$$F = \frac{9}{5}C + 32$$

$$F = \frac{9}{5}(48) + 32$$

$$F = \frac{432}{5} + 32$$

$$F \approx 86.4 + 32$$

$$F \approx 118.4$$

The temperature was approximately  $118.4^{\circ}\text{F}$ .

**BUILD YOUR SKILLS**

- The normal temperature for a dog is from  $99^{\circ}\text{F}$  to  $102^{\circ}\text{F}$ . Ashley's dog has a temperature of  $40^{\circ}\text{C}$ . Convert the temperature to Fahrenheit to calculate if it falls within the normal range.
- Roger is painting the exterior of a house. He should not apply the paint if the temperature is below  $45^{\circ}\text{F}$ . The temperature is  $9^{\circ}\text{C}$ . Is it safe to apply the paint?



2. Convert the following temperatures to degrees Celsius.

a)  $-20^{\circ}\text{F}$

b)  $80^{\circ}\text{F}$

c)  $375^{\circ}\text{F}$

d)  $2^{\circ}\text{F}$

e)  $0^{\circ}\text{F}$

f)  $-2^{\circ}\text{F}$

3. Which is hotter: a blowtorch flame at  $1300^{\circ}\text{C}$  or a candle flame at  $1830^{\circ}\text{F}$ ? By how much is one flame hotter than the other in each scale?

- 
4. When Harry mixes different materials to pave a road, he knows that they must be kept at the following temperatures in degrees Fahrenheit. Calculate the temperatures in degrees Celsius.
- Bituminous material must be between  $200^{\circ}\text{F}$  and  $260^{\circ}\text{F}$ .
  - Water solution must be between  $65^{\circ}\text{F}$  and  $100^{\circ}\text{F}$ .
  - The mixing gel must be between  $160^{\circ}\text{F}$  and  $210^{\circ}\text{F}$ .
5. In 1992, the temperature in Pincher Creek, Alberta, rose from  $-19^{\circ}\text{C}$  to  $22^{\circ}\text{C}$  in just one hour due to a chinook wind. What were these temperatures in degrees Fahrenheit?



## Mass in the Imperial System

# 4.2

### NEW SKILLS: WORKING WITH WEIGHT

The **mass** of an object refers to the quantity of matter in it, and it remains constant, no matter where the object is located. The **weight** of an object is a measure of the force of gravity on the object. On earth, the mass and the weight of an object are essentially the same; on other planets where the pull of gravity is different, weight and mass will not be the same.

The basic units of weight in the imperial system are ton (tn), pound (lb), and ounce (oz).

$$1 \text{ ton (tn)} = 2000 \text{ pounds}$$

$$1 \text{ pound (lb)} = 16 \text{ ounces (oz)}$$

For more details, see page 146 of *MathWorks 10*.

### Example 1

Manuela needs 1 pound 2 ounces of Gruyère cheese, 12 ounces of cheddar cheese, and 11 ounces of Swiss cheese for a fondue recipe. How many pounds of cheese does she need in all?

#### SOLUTION

Add pounds to pounds and ounces to ounces.

$$\begin{array}{r} 1 \text{ pound} + 2 \text{ ounces} \\ + 12 \text{ ounces} \\ + 11 \text{ ounces} \\ \hline 1 \text{ pound } 25 \text{ ounces} \end{array}$$

Change 25 ounces to pounds.

$$16 \text{ ounces} = 1 \text{ pound}$$

$$25 \text{ ounces} = (16 + 9) \text{ ounces}$$

$$25 \text{ ounces} = 1 \text{ pound } 9 \text{ ounces}$$

**mass:** a measure of the quantity of matter in an object

**weight:** a measure of the force of gravity on an object



Total weight = 1 pound 25 ounces

Total weight = 1 pound + 1 pound 9 ounces

Total weight = 2 pounds 9 ounces

Manuela needs 2 lb 9 oz of cheese for her recipe.

#### ALTERNATIVE SOLUTION 1

Change 1 pound 2 ounces to ounces.

$$1 \text{ lb } 2 \text{ oz} = 16 \text{ oz} + 2 \text{ oz}$$

$$1 \text{ lb } 2 \text{ oz} = 18 \text{ oz}$$

Add all the weights.

$$18 \text{ oz} + 12 \text{ oz} + 11 \text{ oz} = 41 \text{ oz}$$

Change to pounds by dividing by 16.

$$41 \text{ oz} = 41 \text{ oz} \times \frac{1 \text{ lb}}{16 \text{ oz}}$$

$$41 \text{ oz} = \left(\frac{41}{16}\right) \text{ lb}$$

$$41 \text{ oz} = \left(2 \frac{9}{16}\right) \text{ lb}$$

$$41 \text{ oz} = 2 \text{ lb } 9 \text{ oz}$$

#### ALTERNATIVE SOLUTION 2

You could also change the ounces to pounds and work with decimals or fractions.

1 lb 2 oz of Gruyère equals 1 plus  $\frac{2}{16}$  lb, or 1.125 lb.

12 oz of cheddar equals  $\frac{12}{16}$  lb, or 0.75 lb.

11 oz of Swiss equals  $\frac{11}{16}$  lb, or 0.6875 lb.

$$\text{Total weight} = 1.125 + 0.75 + 0.6875$$

$$\text{Total weight} \approx 2.56 \text{ lb}$$

**BUILD YOUR SKILLS**

1. Rochelle gave birth to twin boys weighing 6 lb 5 oz and 5 lb 14 oz. What was their total weight?
2. The weight of water is approximately 2 pounds 3 ounces per litre. How much will 8 litres of water weigh?
3. If a basket of raspberries weighs 12 ounces and you need 4 pounds to make jam, how many baskets do you need to buy?

**Example 2**

The cab of Arthur's semi-trailer truck weighs 8.7 tons and the trailer weighs 6.4 tons. If the loaded gross weight of the truck is 21.3 tons, what is the weight of the load:

- a) in tons?
- b) in pounds?

**SOLUTION**

- a) The total weight of the truck is found by adding the weight of the cab and the trailer.

$$8.7 \text{ tn} + 6.4 \text{ tn} = 15.1 \text{ tn}$$

Subtract this amount from the gross weight to get the weight of the load.

$$21.3 \text{ tn} - 15.1 \text{ tn} = 6.2 \text{ tn}$$

The weight of the load is 6.2 tons.

- b) Since 1 ton equals 2000 pounds, find the weight in pounds by multiplying.

$$6.2 \text{ tn} = 6.2 \text{ tn} \times \frac{2000 \text{ lb}}{1 \text{ tn}}$$

$$6.2 \text{ tn} = 12\,400 \text{ lb}$$

The weight of the load is 12 400 pounds.



**Example 3**

A 12-ounce can of vegetables costs \$1.49. A 1 lb 2-oz can of the same vegetables costs \$2.19. Which is the better buy?

**SOLUTION**

Use unit pricing to find the cost per ounce.

12 ounces cost \$1.49.

$$12 \text{ oz} = \$1.49$$

$$\left(\frac{12}{12}\right) \text{ oz} = \frac{\$1.49}{12}$$

$$1 \text{ oz} = \frac{\$1.49}{12}$$

$$1 \text{ oz} = \$0.1242$$

1 lb 2 oz costs \$2.19.

$$1 \text{ lb } 2 \text{ oz} = 16 \text{ oz} + 2 \text{ oz}$$

$$1 \text{ lb } 2 \text{ oz} = 18 \text{ oz}$$

$$18 \text{ oz} = \$2.19$$

$$\left(\frac{18}{18}\right) \text{ oz} = \frac{\$2.19}{18}$$

$$1 \text{ oz} = \frac{\$2.19}{18}$$

$$1 \text{ oz} \approx \$0.1217$$

The 1 lb 2-oz can is the better buy.

**BUILD YOUR SKILLS**

7. An 18-oz jar of peanut butter costs \$3.29, a 28-oz jar costs \$4.79, and a 2.5-lb jar costs \$5.99. Which is the best buy?
8. If knitting yarn costs \$6.24 per 3-oz skein, how much will it cost to knit a sweater that requires 1 pound of yarn? (You cannot buy partial skeins.)

9. About 200 cocoa beans are used to make 1 lb of chocolate. Beans are shipped in 200-lb sacks, which contain about 88 000 beans. How many 1.5-oz chocolate bars can be made from one sack of beans?

---

**Example 4**

Valérie bought 4 pounds 6 ounces of steak for dinner at \$2.74/lb. After removing the excess fat, she had only 4 pounds of meat. What was her true cost per pound?

**SOLUTION**

Change 6 ounces to pounds.

$$1 \text{ lb} = 16 \text{ ounces}$$

$$6 \text{ oz} = (6 \div 16) \text{ lb}$$

$$6 \text{ oz} = 0.375 \text{ lb}$$

She bought 4.375 pounds of meat at \$2.74/lb.

Total cost:

$$4.375 \times \$2.74 = \$11.99$$

Since only 4 pounds were usable, calculate how much each pound cost her.

$$\$11.99 \div 4 = \$3.00$$

Valérie paid approximately \$3.00/lb for the steaks.

**BUILD YOUR SKILLS**

10. Zara buys 8 pounds 12 ounces of strawberries at \$1.98/lb. What is her true cost per pound if 10% of the berries rot before she uses them?
11. Mark bought 8 bags of sand, each weighing 25 lb, for \$1.68/bag. One bag ripped and he lost all the sand. What was his true price per pound of sand?
12. Alyson paid \$28.45 for 24 ounces of coffee beans, but when she checked, the actual weight was 22 ounces. What was her true cost per ounce?



**PRACTISE YOUR NEW SKILLS**

1. Calculate the conversions.

a)  $24 \text{ oz} = \underline{\hspace{2cm}} \text{ lb}$

b)  $7890 \text{ lb} = \underline{\hspace{2cm}} \text{ tn}$

c)  $54 \text{ oz} = \underline{\hspace{1cm}} \text{ lb } \underline{\hspace{1cm}} \text{ oz}$

d)  $6 \text{ lb } 2 \text{ oz} = \underline{\hspace{2cm}} \text{ oz}$

e)  $4.54 \text{ tn} = \underline{\hspace{2cm}} \text{ lb}$

f)  $654 \text{ oz} = \underline{\hspace{1cm}} \text{ lb } \underline{\hspace{1cm}} \text{ oz}$

2. What is the total weight, in pounds and ounces, of six books on a shelf if they weigh 12 oz, 1 lb 7 oz, 1 lb 2 oz, 15 oz, 9 oz, and 1 lb 3 oz?

3. A bakery uses a recipe for oatmeal cookies that calls for 1 lb 4 oz of flour to make 9 dozen cookies. How many ounces of flour are needed to make 3 dozen cookies?
  
  
  
  
  
  
  
  
  
  
4. Kris needs to transport 5 slabs of concrete to an apartment work site. If each slab weighs 46 pounds, Kris weighs 195 pounds, and the truck weighs 1.5 tons, what is the total weight of the loaded truck in pounds?
  
  
  
  
  
  
  
  
  
  
5. Harinder is concerned about the weight that paint might add to a delicate structure he built. He estimates that he needs 1.5 gal of paint and that the structure can withstand 15 lb of weight. The weight of a particular paint is 9 lb/gal. When it dries, the weight is only 5.4 lb/gal. Can Harinder paint his structure without having it collapse?

6. U-pick organic blueberries sell for \$20.00 for a 12-pound box.

a) How much would 1 pound cost?

b) How much would 12 ounces cost?

7. What is the true cost per pound of a 10-pound box of oranges if the original price of the box was \$12.99 and  $\frac{1}{4}$  of them had to be thrown away because they were mouldy?

## Mass in the Système International

# 4.3

### NEW SKILLS: WORKING WITH SI UNITS OF MASS

In the Système International (SI), the **kilogram** is the basic unit of mass, but it is commonly used for weight as well.

$$1000 \text{ grams (g)} = 1 \text{ kilogram (kg)}$$

$$1000 \text{ milligrams (mg)} = 1 \text{ gram}$$

$$1 \text{ tonne (t)} = 1000 \text{ kilograms}$$

For more details, see page 154 of *MathWorks 10*.

#### Example 1

A recipe for cornbread calls for 120 g of flour, 170 g of cornmeal, and 50 g of sugar. If you double the recipe, what is the total weight of the dry ingredients?

#### SOLUTION

You can either add the weights together and then double the sum, or double the weights and then add them together.

$$\text{Flour: } 2 \times 120 \text{ g} = 240 \text{ g}$$

$$\text{Cornmeal: } 2 \times 170 \text{ g} = 340 \text{ g}$$

$$\text{Sugar: } 2 \times 50 \text{ g} = 100 \text{ g}$$

Add the weights of all the ingredients.

$$240 \text{ g} + 340 \text{ g} + 100 \text{ g} = 680 \text{ g}$$

There are 680 g of dry ingredients in the doubled recipe.

**kilogram:** the mass of one litre of water at 4°C

Note that a tonne (t) is not the same as a ton (tn). A tonne is sometimes referred to as a metric ton.

**BUILD YOUR SKILLS**

1. What is the total weight of a loaded truck if the truck weighs 2.6 tonnes and it is loaded with 15 skids of boxes that weigh 210 kilograms each? Give your answer in tonnes.
2. Irène needs 1.6 kg of tomatoes to make her grandmother's recipe for ratatouille. She has baskets of tomatoes that weigh 256 g, 452 g, 158 g, and 320 g. How many more grams of tomatoes does she need?
3. Genoa salami sells for \$1.79/100 g at the deli.
  - a) How much will 350 g cost?
  - b) What is the price per kilogram?

## NEW SKILLS: WORKING WITH MASS/WEIGHT CONVERSION BETWEEN IMPERIAL AND SI

In this section, you will need to work with the relationship between the SI and the imperial units of weight. One kilogram weighs about 2.2 lb. You can also use this information to convert from grams to ounces and tonnes to tons.

For more details, see page 157 of *MathWorks 10*.

### Example 2

Lorinda is baking apple pies. According to her recipe, she needs 6 pounds of apples. The bag of apples she bought only shows the weight in kilograms. How many kilograms of apples does she need?

#### SOLUTION

$$2.2 \text{ lb} = 1 \text{ kg}$$

$$1 \text{ lb} = \frac{1 \text{ kg}}{2.2}$$

$$6 \text{ lb} = 6 \times \frac{1 \text{ kg}}{2.2}$$

$$6 \text{ lb} \approx 2.7 \text{ kg}$$

She will need approximately 2.7 kg of apples.

To estimate a conversion from pounds to kilograms, you can think of a pound as being about  $\frac{1}{2}$  kg.



**Example 3**

The cost of bananas is \$0.49/lb at one store, but you see an advertisement for bananas on sale at another store for \$1.05/kg. Which is the better buy?

**SOLUTION**

Convert the price of bananas at the first store to kilograms.

1 lb costs \$0.49.

1 kg = 2.2 lb

Therefore, 1 kg costs 2.2 times the cost of 1 lb.

$$2.2 \times \$0.49 = \$1.08$$

One kilogram of bananas at the first store costs about \$1.08. The sale at the second store is a better buy.

**BUILD YOUR SKILLS**

- How much does 1 pound of beef cost if the butcher shop sells it for \$9.74/kg?
- Which is the better buy: 200 g of coffee beans at \$3.85 or 1 pound at \$9.60?



9. The dosage of a certain medicine is 0.05 mg/kg of weight. Tom weighs 185 lbs.

a) How many milligrams of the medicine should he take?

b) If the medicine costs \$1.95/mg, what will his dosage cost?

### **PRACTISE YOUR NEW SKILLS**

1. Convert the following weights.

a) 2.5 t = \_\_\_\_\_ kg

b) 2.8 kg = \_\_\_\_\_ g

c) 125 g = \_\_\_\_\_ kg

d)  $2.4 \text{ g} = \underline{\hspace{2cm}} \text{ kg}$

e)  $1 \text{ t} = \underline{\hspace{2cm}} \text{ lb}$

f)  $3.6 \text{ tn} = \underline{\hspace{2cm}} \text{ kg}$

2. How many tons are in 1 tonne?
  
  
  
  
  
  
  
  
  
  
3. What is the total weight in grams of 3 packages of nuts weighing 1.2 kg, 0.75 kg, and 1.5 kg?
  
  
  
  
  
  
  
  
  
  
4. Win weighs 78 kg and his dog weighs 18 kg. If his truck weighs 1.9 t and there are 5 boxes of books each weighing 9.8 kg in the truck, what is the total weight of the truck, including Win, his dog, and the books?



## Making Conversions

# 4.4

### NEW SKILLS: WORKING WITH CONVERSIONS BETWEEN MEASURES OF VOLUME AND WEIGHT

You have converted measures from one unit to another, within the SI or imperial system, or between them.

Here, you will convert from a unit of volume to a unit of weight. For example, grain is often measured in bushels, a volume measure, but its weight may be needed to judge whether it is a safe load for a truck. Each grain has a different weight, so conversions between bushels and weight depend on knowing the conversion factor.

For more details, see page 162 of *MathWorks 10*.

1 bushel = 2220 in<sup>3</sup>  
or approximately  
8 gallons.

#### Example 1

How many bushels (bu) of flax seed are there in 2.4 tonnes, if the conversion factor is 39.368 bushels/tonne?

#### SOLUTION

A conversion factor of 39.368 means that there are 39.368 bushels of flax seed per tonne. To find the number of bushels, multiply.

$$2.4 \text{ t} \times \frac{39.368 \text{ bu}}{1 \text{ t}} = x \text{ bu}$$

$$2.4 \times 39.368 = 94.5$$

There are approximately 94.5 bushels of flax seed.

**BUILD YOUR SKILLS**

1. Laila bought 5 bushels of sunflower seeds. If the conversion factor is 73.487 bu/t, what is the weight of the sunflower seeds:
  - a) in kilograms?
  
  
  
  
  
  
  
  
  
  
  - b) in pounds?
  
2. The conversion factor for white beans is 36.744, and for corn it is 39.368. Which weighs more per unit volume?
  
  
  
  
  
  
  
  
  
  
3. If Jore gets \$195.76 per metric ton for wheat, how much does he earn per bushel (conversion factor 36.744 bu/t)?



**NEW SKILLS: WORKING WITH CONVERSION BETWEEN SI AND IMPERIAL UNITS OF WEIGHT**

You can use the following equivalencies to convert between SI and imperial units.

$$1 \text{ lb} \approx 0.45 \text{ kg}$$

$$1 \text{ oz} \approx 28.3 \text{ g}$$

$$1 \text{ tn} \approx 0.9 \text{ t}$$

**BUILD YOUR SKILLS**

- Alphonse is making chicken kebabs for 14 people. His recipe suggests about 7 oz of chicken per person. At the grocery store, the weight of chicken is labelled in kilograms. How much chicken does Alphonse need to buy?
- A crane can lift a maximum of 5 t. Sandstone weighs about 150 lb per cubic foot, and a container contains 70 cubic feet of sandstone. Can the crane be used to load the container onto a train?

9. Josephine is sending a gift of a bottle of maple syrup that weighs 3 lb, and 3 packages of smoked salmon jerky that each weigh 100 g. If the package's total weight is less than 2 kg, she can ship it at a cheaper rate. Will she be able to do so?

**PRACTISE YOUR NEW SKILLS**

1. If 1 bushel is approximately 2220 cubic inches, approximately how many bushels of grain are there in a bin that is 8 feet by 8 feet by 4 feet?







**CHAPTER TEST**

1. Convert the following temperatures.

a)  $25^{\circ}\text{C} = \underline{\hspace{2cm}}^{\circ}\text{F}$

b)  $25^{\circ}\text{F} = \underline{\hspace{2cm}}^{\circ}\text{C}$

c)  $-40^{\circ}\text{C} = \underline{\hspace{2cm}}^{\circ}\text{F}$

d)  $-25^{\circ}\text{F} = \underline{\hspace{2cm}}^{\circ}\text{C}$

e)  $405^{\circ}\text{F} = \underline{\hspace{2cm}}^{\circ}\text{C}$

f)  $45^{\circ}\text{C} = \underline{\hspace{2cm}}^{\circ}\text{F}$

2. A welder's electrical arc has a temperature ranging from  $500^{\circ}\text{C}$  to  $20\,000^{\circ}\text{C}$ . What is this in degrees Fahrenheit?

3. Convert the following weights.

a) 12 lb 4 oz = \_\_\_\_\_ oz

b) 2.3 tn = \_\_\_\_\_ lb

c) 5284 lb = \_\_\_\_\_ tn \_\_\_\_\_ lb

d)  $3\frac{3}{4}$  lb = \_\_\_\_\_ oz

e) 165 oz = \_\_\_\_\_ lb

f) 454 g = \_\_\_\_\_ lb

4. It is estimated that recycling 1 ton of paper saves about 17 trees. About how many trees are saved if 8254 tons of paper are recycled?

5. Eva bought 3 rainbow trout for dinner. They weighed 3 lb 5 oz, 2 lb 12 oz, and 3 lb 8 oz. She cut off the heads and the tails and was left with 8 lb 2 oz. What was the amount of waste?
6. The weight of a piece of raw silk that is 100 yards long by 1.25 yards wide (standard width) is about 38 pounds. The weight of an equal amount of habutai silk is about 12 pounds. If Katharine bought pieces of raw silk and habutai silk that were both 12.5 yards long, how much would they weigh together?
7. A robin's egg weighs about 70 g. How many eggs would it take to make 1 kilogram?

8. Huang bought 12 boxes of floor tiles that weigh 288 pounds each. How much is this in kilograms?

9. Soybeans have a conversion factor of 36.744 (bu/t). How much do 45 bushels weigh?

# Chapter 5

## Angles and Parallel Lines



Angles and parallel lines provide BC's Liard River Bridge with strength, stability, and visual appeal. The bridge was built in 1942.

### 5.1

## Measuring, Drawing, and Estimating Angles

### REVIEW: WORKING WITH ANGLES

In this section, you will review types of angles and how to classify them.

An angle is formed when two rays meet at a point called the vertex. Angles are usually measured in degrees using a protractor. Angle measures range from  $0^\circ$  to  $360^\circ$ .

Angles are:

- acute, if their measure is between  $0^\circ$  and  $90^\circ$ ;
- right, if their measure is  $90^\circ$ ; the two rays are perpendicular to each other;
- obtuse, if their measure is between  $90^\circ$  and  $180^\circ$ ;
- straight, if their measure is  $180^\circ$ ; and
- reflex, if their measure is between  $180^\circ$  and  $360^\circ$ .

**Example 1**

Identify the type of angle: acute, right, obtuse, straight, or reflex.

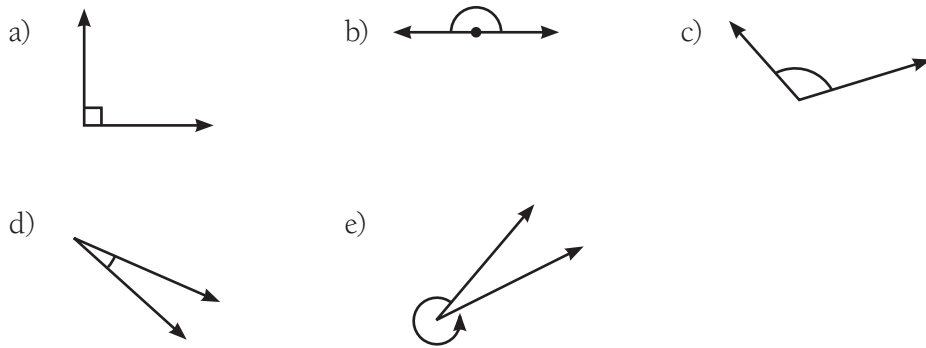
**SOLUTION**

- a) This is a right angle.  
 b) This is a straight angle.  
 c) This is an obtuse angle.  
 d) This is an acute angle.  
 e) This is a reflex angle.

**BUILD YOUR SKILLS**

1. Identify the type of angle: acute, right, obtuse, straight, or reflex.

- a)  $68^\circ$       b)  $215^\circ$       c)  $91^\circ$       d)  $32^\circ$
- e)  $180^\circ$       f)  $99^\circ$       g)  $195^\circ$       h)  $265^\circ$



## NEW SKILLS: WORKING WITH REFERENT ANGLES

In many jobs, people have to draw angles or estimate their measure. To estimate the size of an angle, you can use referent angles, which are angles that are easy to visualize. You can use these referents to determine the approximate size of a given angle.

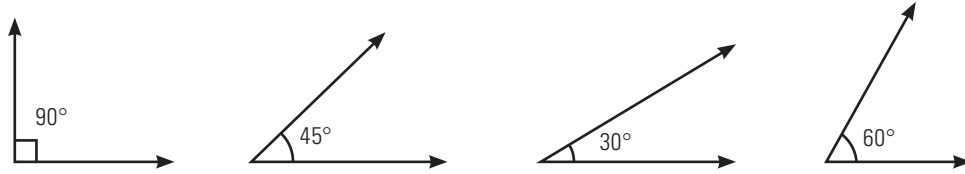

For more details, see page 174 of *MathWorks 10*.

### Example 2

Use the referents above to estimate the size of each of the following angles. Use a protractor to check your answers.

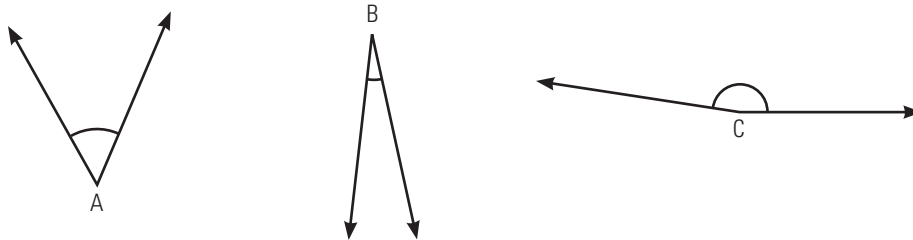

### SOLUTION

$\angle A$  is slightly bigger than the  $45^\circ$  referent. It is probably about  $50^\circ$ .

$\angle B$  is less than  $30^\circ$ , so it is probably between  $15^\circ$  and  $20^\circ$ .

$\angle C$  is close to a straight angle but it is probably about  $10^\circ$  less. Therefore,  $\angle C$  is approximately  $170^\circ$ .

Using a protractor, measure the angles.

$\angle A$  is  $52^\circ$ .

$\angle B$  is  $18^\circ$ .

$\angle C$  is  $172^\circ$ .

$\angle$  is a symbol used to indicate an angle.

**BUILD YOUR SKILLS**

2. Use the referents to determine the approximate size of the following angles.

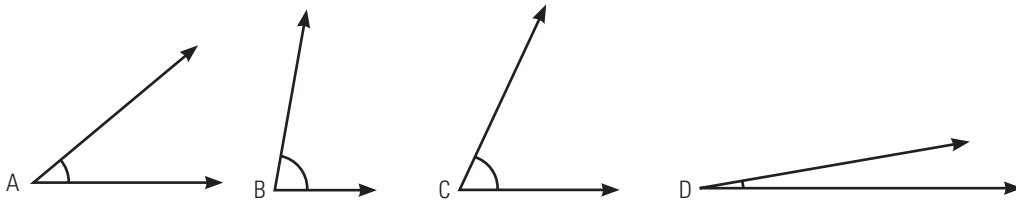

3. What is the approximate angle of the railing on the stairs?

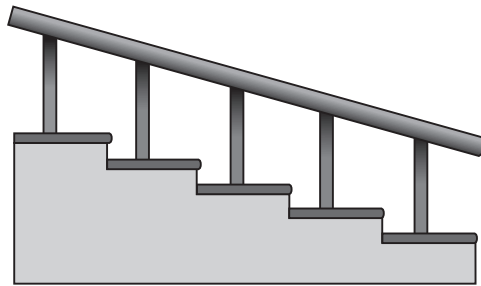

4. Use the referents in the New Skills section to determine the approximate size of the following angles.

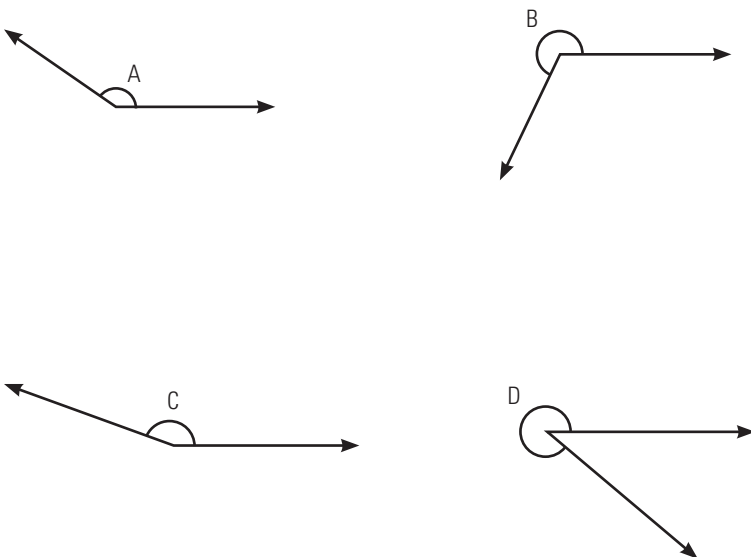

5. Jason is doing a survey of a city block. What is the approximate angle between his sightings of the two buildings?

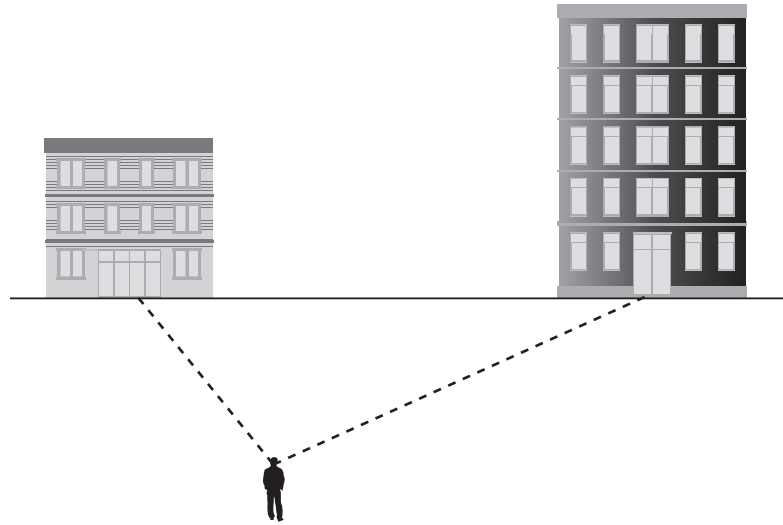

### Example 3

**complementary angles:**

two angles that have measures that add up to  $90^\circ$

**supplementary angles:**

two angles that have measures that add up to  $180^\circ$

Given each of the following angles, determine the size of the **complement** and/or the size of the **supplement** (if they exist).

- a)  $75^\circ$
- b)  $43^\circ$
- c)  $103^\circ$
- d)  $87^\circ$
- e)  $300^\circ$

Two angles with the same measure are referred to as congruent.

### SOLUTION

To find the complement, subtract the angle measure from  $90^\circ$ .

To find the supplement, subtract the angle measure from  $180^\circ$ .

a) Complement:

$$90^\circ - 75^\circ = 15^\circ$$

Supplement:

$$180^\circ - 75^\circ = 105^\circ$$

b) Complement:

$$90^\circ - 43^\circ = 47^\circ$$

Supplement:

$$180^\circ - 43^\circ = 137^\circ$$

c) Complement: The angle is already greater than  $90^\circ$  so there is no complement.

Supplement:

$$180^\circ - 103^\circ = 77^\circ$$

d) Complement:

$$90^\circ - 87^\circ = 3^\circ$$

Supplement:

$$180^\circ - 87^\circ = 93^\circ$$

e) The angle is greater than  $180^\circ$ , so it has no complement or supplement.

### BUILD YOUR SKILLS

6. Fill in the chart with the complement and the supplement of each angle, if they exist. If they don't exist, state why.

ANGLE COMPLEMENTS AND SUPPLEMENTS		
Angle	Complement	Supplement
$45^\circ$		
$78^\circ$		
$112^\circ$		
$160^\circ$		
$220^\circ$		

7. The complement of an angle is  $58^\circ$ .

a) What is the size of the angle?

b) What is the supplement of the angle?

8. The complement of an angle is  $0^\circ$ .

a) What is the size of the angle?

b) What is the size of the supplement of the angle?

## NEW SKILLS: WORKING WITH TRUE BEARING

In navigation and map-making, people often measure angles from the vertical, or north. The angle, measured in a clockwise direction from a line pointing north, is referred to as the **true bearing**. Straight north has a bearing of  $0^\circ$ .

For more details, see page 182 of *MathWorks 10*.

**true bearing:** the angle measured clockwise between true north and an intended path or direction, expressed in degrees

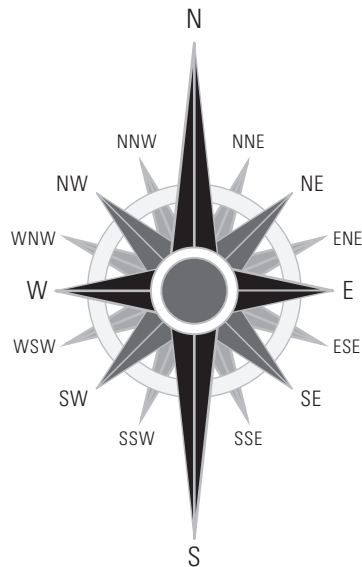

### Example 4

A boat is heading directly southwest. What is its true bearing?

#### SOLUTION

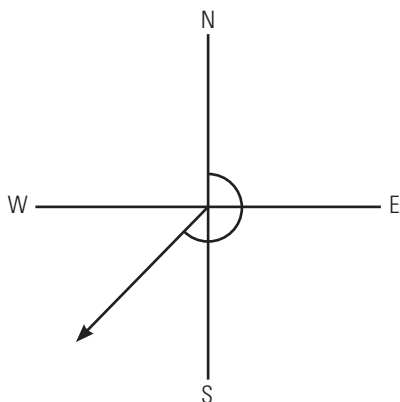

If the boat is heading southwest, measuring from the vertical will give you an obtuse angle of  $225^\circ$  ( $45^\circ$  beyond a straight angle).

**BUILD YOUR SKILLS**

9. If a boat is travelling  $25^\circ$  south of straight east, what is its true bearing?
  
  
  
  
  
  
  
  
  
  
10. What is the true bearing of a boat travelling south?
  
  
  
  
  
  
  
  
  
  
11. What is the true bearing of a boat travelling north-northwest?

**PRACTISE YOUR NEW SKILLS**

1. Identify the type of angle: acute, right, obtuse, straight, or reflex.
  - a)  $56^\circ$
  - b)  $91^\circ$
  - c)  $270^\circ$
  - d)  $170^\circ$
  - e)  $43^\circ$
  - f)  $192^\circ$

2. Estimate, using referents, the size of the angles indicated in the diagrams.

a)

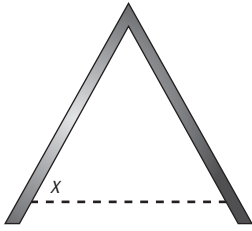

b)

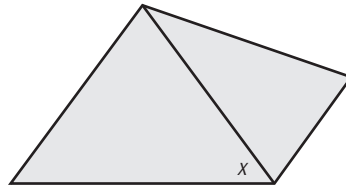

c)

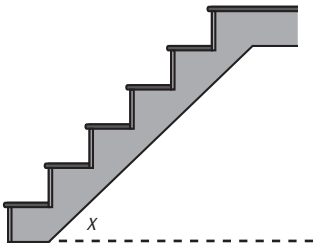

d)

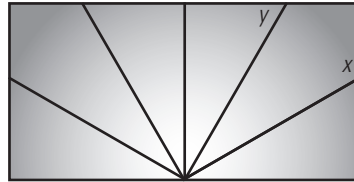

3. If Renata cuts a rectangular tile diagonally, one of the acute angles formed is  $65^\circ$ . What is the size of the other acute angle?

4. Pete is laying irregularly shaped paving stones. He needs to find one to fit in position A. Approximately what size of angle will it have?

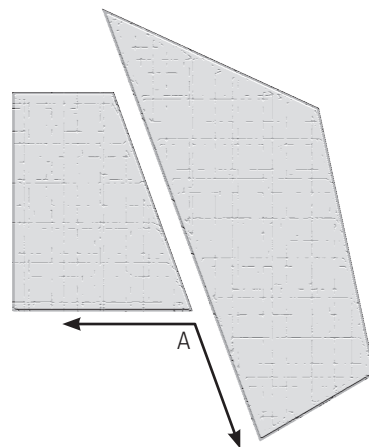



5. On the map below, what is the bearing from the following points?

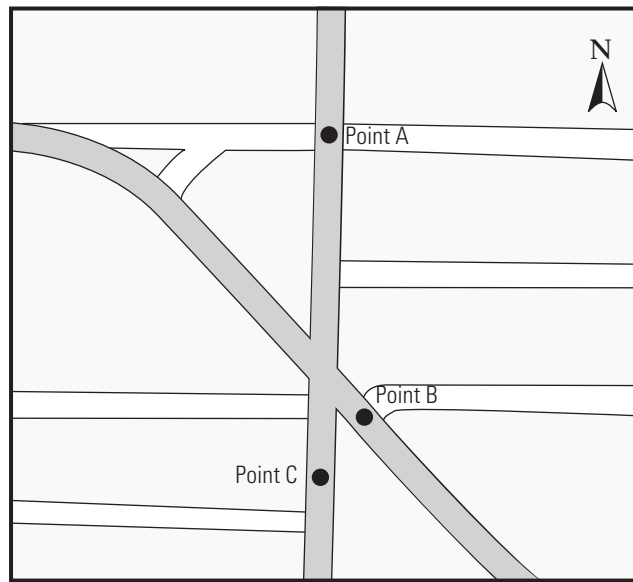

a) A to B

b) B to C

# Angle Bisectors and Perpendicular Lines

## 5.2

### NEW SKILLS: WORKING WITH ANGLE BISECTORS

To bisect something is to cut it into two equal parts. An angle is bisected by a ray that divides it into two angles of equal measure. The ray that divides the angle is called an **angle bisector**.

Perpendicular lines are two lines that form a right angle. A right angle ( $90^\circ$ ) can be thought of as a bisected straight ( $180^\circ$ ) angle. The process used to draw perpendicular lines is the same as drawing angle bisectors because a perpendicular line bisects a straight angle.

For more details, see page 187 of *MathWorks 10*.



### Example 1

Bisect  $\angle ABC$  using a straight edge and compass.

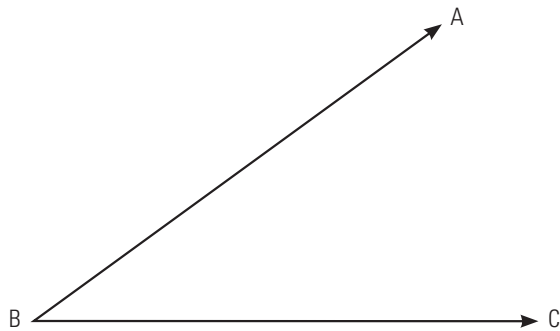

**SOLUTION**

To draw a ray,  $BD$ , that bisects  $\angle ABC$ , follow these steps:

- With the compass point at  $B$ , draw an arc to intersect  $BA$  and  $BC$  at  $X$  and  $Y$ , respectively.
- With the compass point at  $X$  and the radius more than half of  $XY$ , draw a small arc in the interior of  $\angle ABC$ .
- With the same radius and compass point at  $Y$ , draw a small arc to intersect this arc at  $D$ .
- Join  $B$  and  $D$ .

$BD$  is the bisector of  $\angle ABC$ .

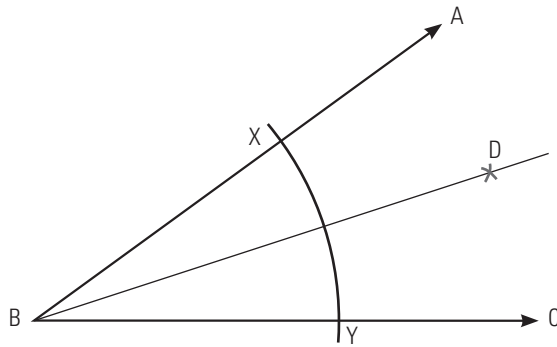
**BUILD YOUR SKILLS**

1. If a right angle is bisected, what is the size of each angle?

2. Bisect the given angles using a straight edge and compass.

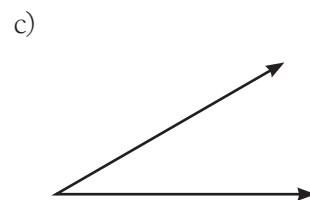
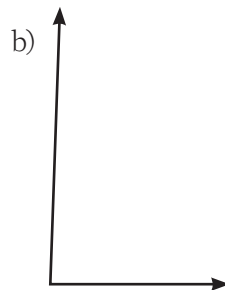
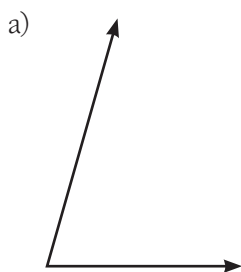

3. An angle is bisected. Each resulting angle is  $78^\circ$ . How big was the original angle?
  
4. The size of one resulting angle after the original angle is bisected is equal to the supplement of the original angle. What is the measure of the original angle?

### Example 2

Using a protractor, determine which of the following lines are perpendicular.

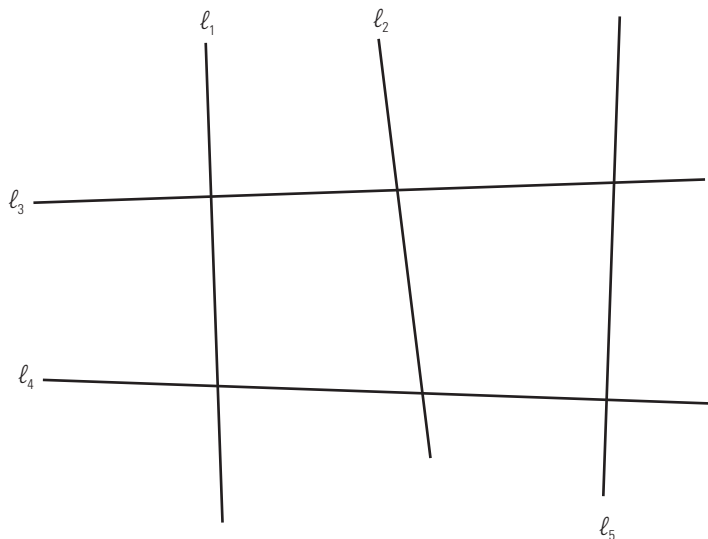

### SOLUTION

The angles formed between  $l_1$  and  $l_3$  are each  $90^\circ$ , so  $l_1$  and  $l_3$  are perpendicular.

The angles formed between  $l_1$  and  $l_4$  are not  $90^\circ$ , so  $l_1$  and  $l_4$  are not perpendicular.

The angles formed between  $l_2$  and  $l_3$  are not  $90^\circ$ , so  $l_2$  and  $l_3$  are not perpendicular.

The angles formed between  $l_2$  and  $l_4$  are not  $90^\circ$ , so  $l_2$  and  $l_4$  are not perpendicular.

The angles formed between  $l_5$  and  $l_3$  are not  $90^\circ$ , so  $l_5$  and  $l_3$  are not perpendicular.

The angles formed between  $l_5$  and  $l_4$  are each  $90^\circ$ , so  $l_5$  and  $l_4$  are perpendicular.

In the workplace, carpenters often use framing squares and levels to ensure that they have right angles. A framing square is a tool that is a right angle.

**BUILD YOUR SKILLS**

5. A crooked table leg makes an angle of  $86.7^\circ$  with the tabletop. How much must the carpenter move the leg so that it is perpendicular to the tabletop?

6. At what approximate angle does the hill incline from the horizontal?



7. A carpenter is inlaying different types of wood on a tabletop. What must be the size of angles  $a$ ,  $b$ ,  $c$ , and  $d$ ?

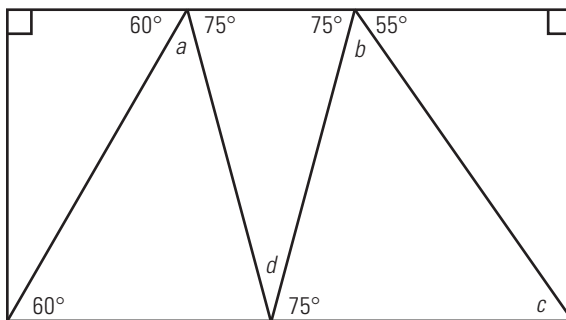

## PRACTISE YOUR NEW SKILLS

1. Use a protractor to determine whether these lines are perpendicular.

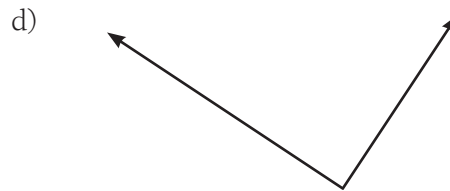
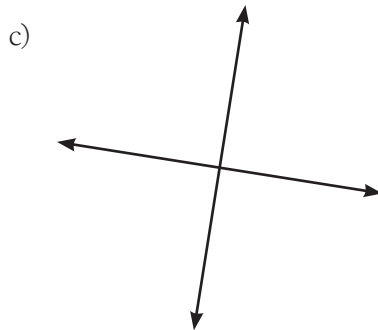
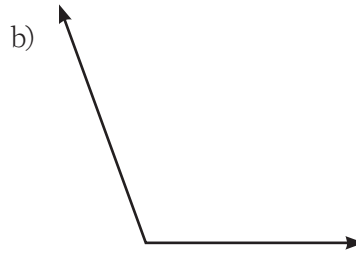
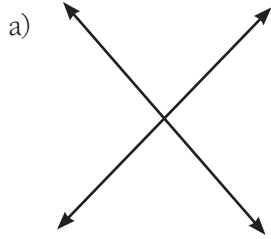

2. Complete the following table.

ANGLE CALCULATIONS			
Angle	Complement	Supplement	Resulting angle measure after the angle is bisected
73°			
	12°		
15°			
		132°	
90°			
			34°
	49°		
			68°
		100°	
			127°

3. Kaleb is edging a garden bed with square tiles. In the corner shown below, he wants two congruent tiles. At what angle must he cut the tiles so that they fit?

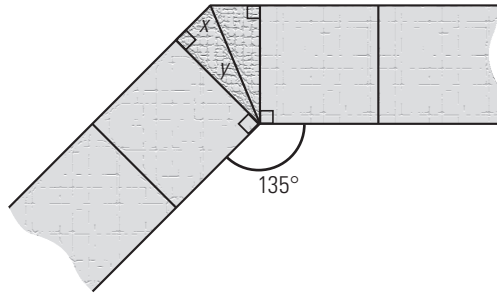

4. Calculate the size of the indicated angles. Name as many pairs of complementary and supplementary angles as possible.

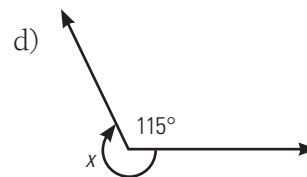
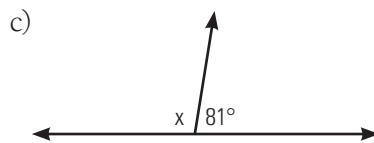
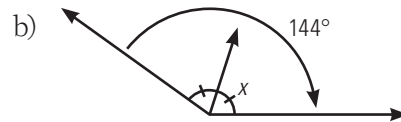
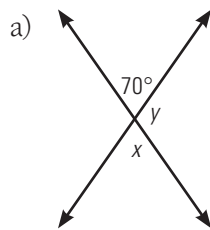

5. The angle at the peak of a roof is  $135^\circ$ . Calculate the measure of the angle formed by the rafter and the king post.

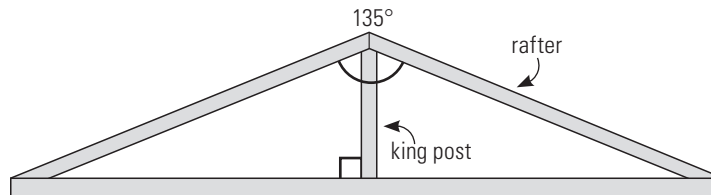

## Non-Parallel Lines and Transversals

# 5.3

### NEW SKILLS: WORKING WITH ANGLES FORMED BY INTERSECTING LINES

A line that intersects two other lines at two distinct points is a **transversal**. When two non-parallel lines are intersected by a transversal, they form angles of varying sizes.

Consider the diagram below:  $t$  is a transversal that intersects  $l_1$  and  $l_2$ .

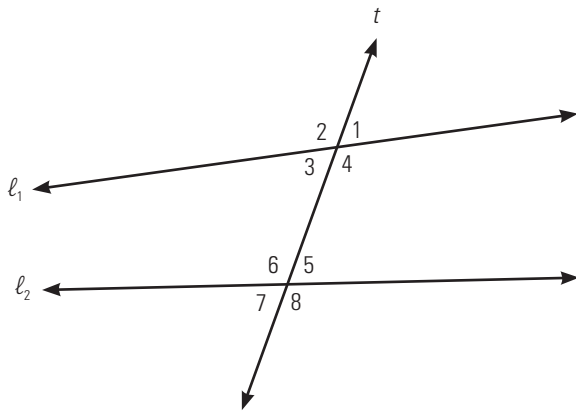

Eight angles are formed.

- $\angle 1$  and  $\angle 5$ , and  $\angle 4$  and  $\angle 8$ ,  $\angle 2$  and  $\angle 6$ , and  $\angle 3$  and  $\angle 7$  are pairs of **corresponding** angles.
- $\angle 1$  and  $\angle 3$ , and  $\angle 2$  and  $\angle 4$ ,  $\angle 5$  and  $\angle 7$ , and  $\angle 6$  and  $\angle 8$  are pairs of **vertically opposite** angles.
- $\angle 3$  and  $\angle 5$ , and  $\angle 4$  and  $\angle 6$  are pairs of **alternate interior** angles.
- $\angle 2$  and  $\angle 8$ , and  $\angle 1$  and  $\angle 7$  are pairs of **alternate exterior** angles.
- $\angle 3$  and  $\angle 6$ , and  $\angle 4$  and  $\angle 5$  are pairs of interior angles on the same side of the transversal.
- $\angle 1$  and  $\angle 8$ , and  $\angle 2$  and  $\angle 7$  are pairs of exterior angles on the same side of the transversal.

For more details, see page 198 of *MathWorks 10*.

**transversal:** a line that intersects two or more lines

**corresponding angles:** two angles that occupy the same relative position at two different intersections

**vertically opposite angles:** angles created by intersecting lines that share only a vertex

**alternate interior angles:** angles in opposite positions between two lines intersected by a transversal and also on alternate sides of the same transversal

**alternate exterior angles:** angles in opposite positions outside two lines intersected by a transversal



A transversal is not necessarily one line segment in a specific drawing. In this figure, there are several lines that intersect other lines. These can be considered transversals.

### Example 1

In the following diagram, identify each of the following, and specify which lines and transversals you are using.

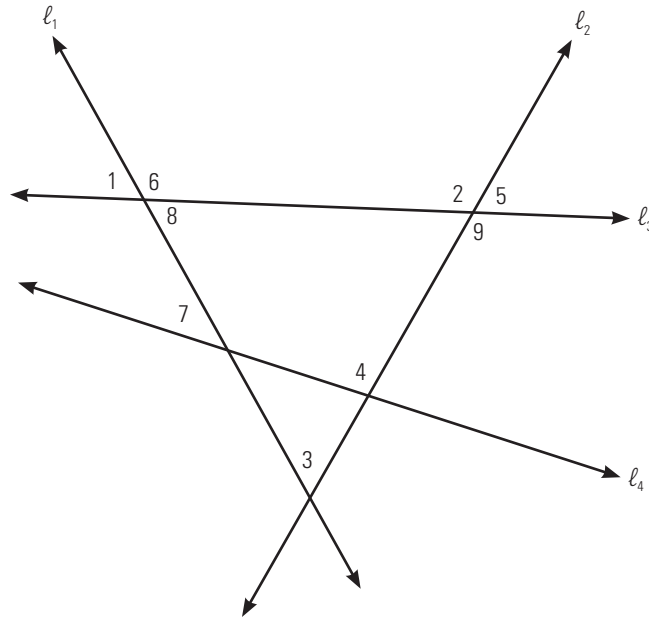

- an interior angle on the same side of the transversal as  $\angle 6$
- an angle corresponding to  $\angle 2$
- an angle corresponding to  $\angle 4$
- an alternate interior angle to  $\angle 4$

### SOLUTION

- Using  $l_1$  and  $l_2$ , with transversal  $l_3$ ,  $\angle 2$  and  $\angle 6$  are interior angles on the same side of the transversal.
- Using  $l_1$  and  $l_2$ , with transversal  $l_3$ ,  $\angle 1$  corresponds to  $\angle 2$ .
- Using  $l_1$  and  $l_2$ , with transversal  $l_4$ ,  $\angle 7$  corresponds to  $\angle 4$ .
- Using  $l_3$  and  $l_4$ , with transversal  $l_2$ ,  $\angle 4$  and  $\angle 9$  are alternate interior angles.

## BUILD YOUR SKILLS

1. In the diagram below, identify the relationship between each pair of angles.

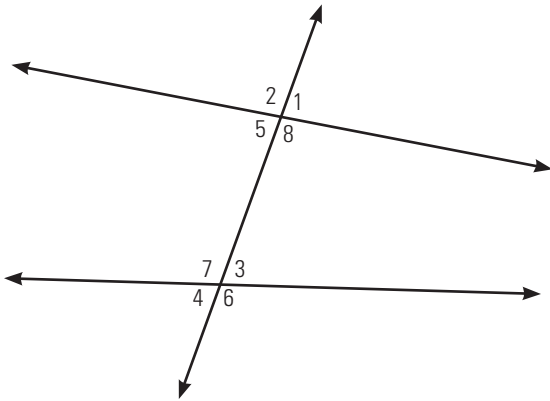

- a)  $\angle 7$  and  $\angle 8$
  - b)  $\angle 2$  and  $\angle 7$
  - c)  $\angle 1$  and  $\angle 6$
  - d)  $\angle 5$  and  $\angle 7$
2. Given the diagram below, identify the following angles.

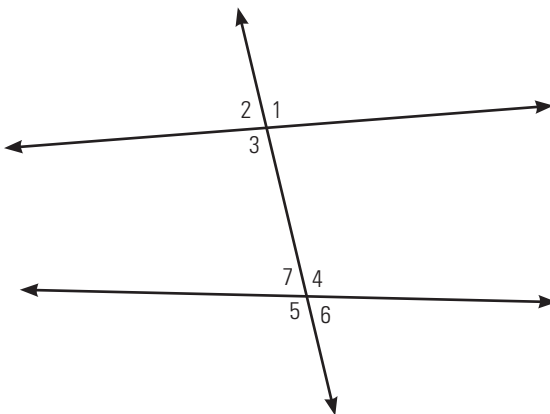

- a) an alternate exterior angle to  $\angle 2$
- b) an interior angle on the same side of the transversal as  $\angle 7$
- c) an alternate interior angle to  $\angle 4$
- d) an angle corresponding to  $\angle 5$

3. Identify each of the following angles. Name the two lines and the transversal you are using.

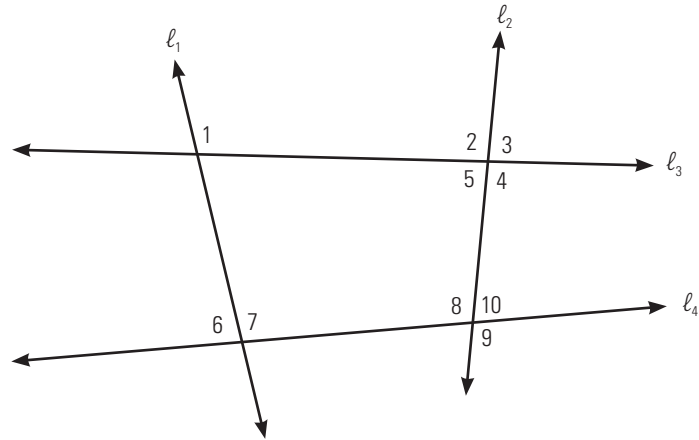

- two angles corresponding to  $\angle 1$
- an interior angle on the same side of the transversal as  $\angle 10$
- an alternate interior angle to  $\angle 5$
- two interior angles on the same side of the transversal as  $\angle 8$

### Example 2

In the diagram below, measure and record the sizes of the angles. Identify pairs of equal angles and state why they are equal.

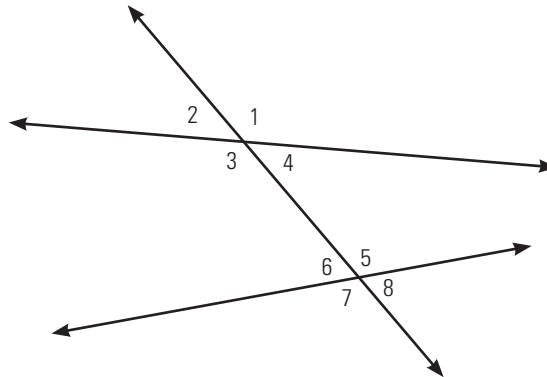

### SOLUTION

Use a protractor to measure the angles.

$\angle 1$  and  $\angle 3$  measure  $125^\circ$

$\angle 2$  and  $\angle 4$  measure  $55^\circ$

$\angle 5$  and  $\angle 7$  measure  $120^\circ$

$\angle 6$  and  $\angle 8$  measure  $60^\circ$

These are each pairs of vertically opposite angles.

**BUILD YOUR SKILLS**

4. Look at the diagram below. Identify two transversals that intersect both AB and AD.

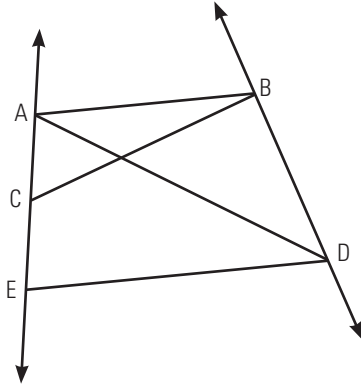

5. In the diagram below, can  $t$  be a transversal that intersects  $\ell_1$  and  $\ell_2$ ? State why or why not.

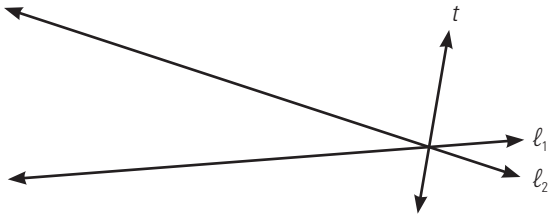

6. In the diagram below,  $t$  is a transversal that intersects  $l_1$  and  $l_2$ . Name another pair of lines and their transversal.

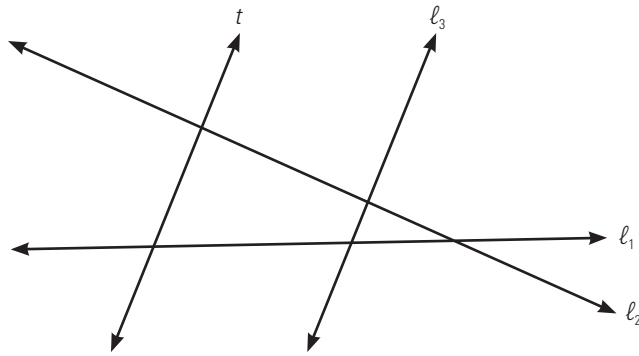
**PRACTISE YOUR NEW SKILLS**

1. In the diagram below, where  $t$  is the transversal, identify two pairs of each of the following angles.

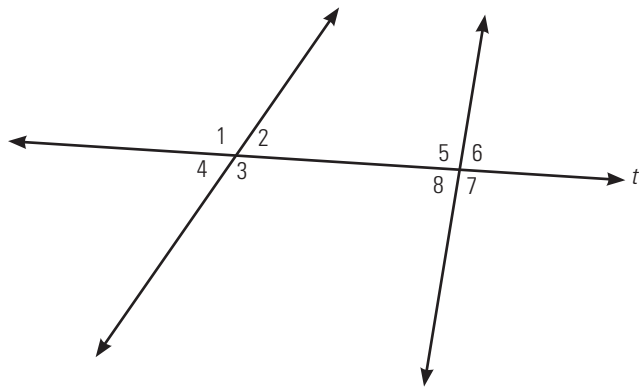

- alternate interior angles
- corresponding angles
- interior angles on the same side of the transversal

2. A flashlight shines down onto a floor as shown in the diagram below. If the outer rays are considered to be two lines and the floor is a transversal, name a pair of corresponding angles.

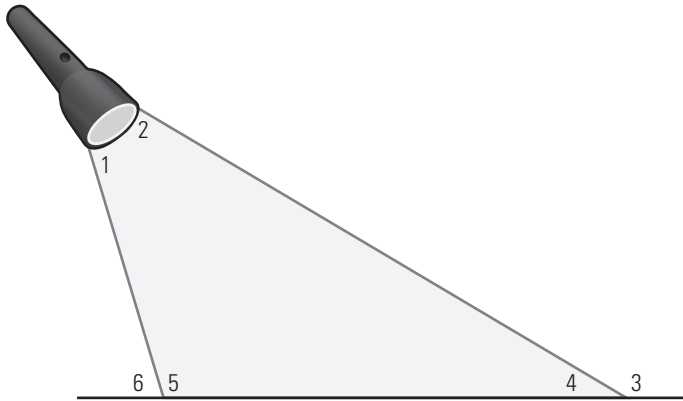

3. In the diagram below, identify which line is a transversal that intersects  $l_1$  and  $l_2$  that makes the following relationships between the pairs of angles.
- $\angle 1$  and  $\angle 2$  a pair of corresponding angles
  - $\angle 3$  and  $\angle 4$  a pair of alternate interior angles

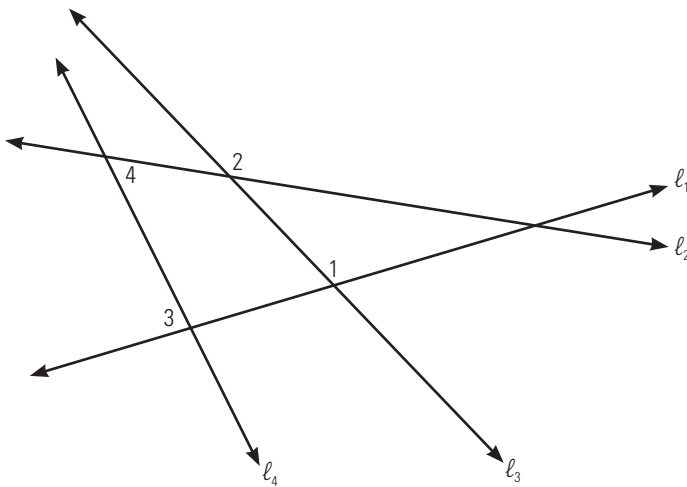

4. In the diagram below, calculate the sizes of each of the interior angles. What is their sum?

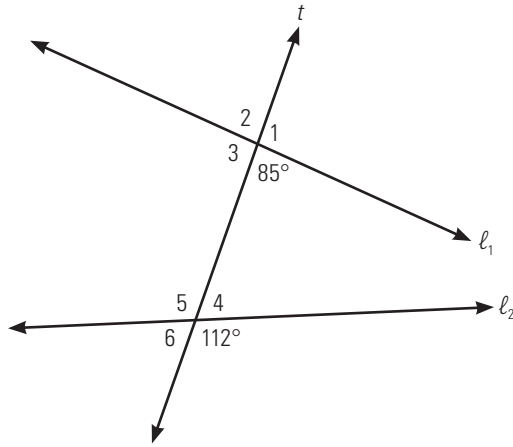

5. Calculate the sizes of the six angles indicated in the figure.

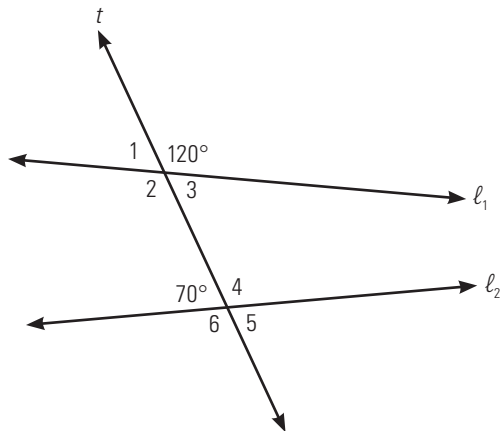

## Parallel Lines and Transversals

## 5.4

**NEW SKILLS: WORKING WITH ANGLES FORMED BY PARALLEL LINES INTERSECTED BY A TRANSVERSAL**

If two parallel lines are intersected by a transversal:

- the alternate interior angles are equal;
- the corresponding angles are equal; and
- the interior angles on the same side of the transversal are supplementary.

If you know that, given two lines cut by a transversal:

- alternate interior angles are equal; or
- corresponding angles are equal; or
- interior angles on the same side of the transversal are supplementary;

then you can conclude that the lines are parallel.

For more details, see page 209 of *MathWorks 10*.

**Example 1**

Consider the diagram below, in which  $l_1$  is parallel to  $l_2$ . What are the measures of the three indicated angles? Explain how you reached your answers.

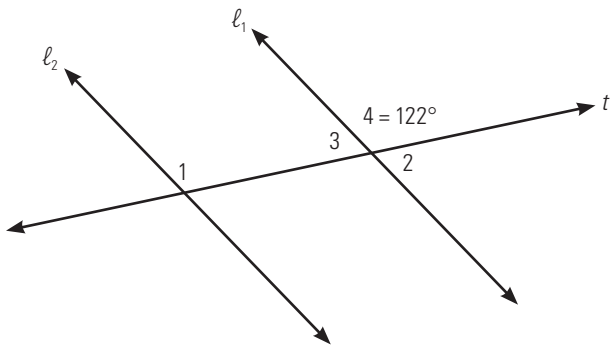
**SOLUTION**

$\angle 1$  measures  $122^\circ$  because it corresponds to  $\angle 4$ .

$\angle 2$  measures  $58^\circ$  because it forms a straight angle with  $\angle 4$ .

$\angle 3$  measures  $58^\circ$  because it is vertically opposite  $\angle 2$ .



The order in which you find the angle measures is important in explaining your reasoning.

### ALTERNATIVE SOLUTION

There may be more than one reason for stating why two angles are equal.

$\angle 3$  is  $58^\circ$  because it forms a straight angle with  $\angle 4$ .

$\angle 2$  is  $58^\circ$  because it is vertically opposite  $\angle 3$ .

$\angle 1$  is  $122^\circ$  because it is an interior angle on the same side of a transversal as  $\angle 3$ .

### BUILD YOUR SKILLS

- In the diagram below,  $l_1$  is parallel to  $l_2$ . State the measures of the indicated angles and explain your reasoning.

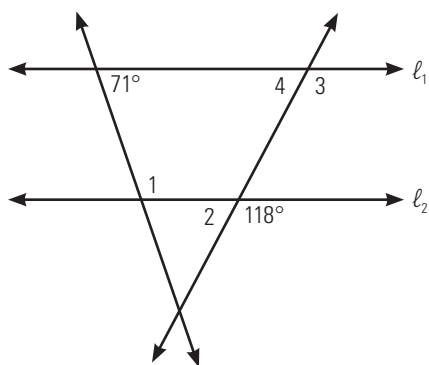

- What are the measures of the interior angles in the trapezoid shown below? (Hint: Be careful of the order in which you calculate the angles.)



3. Quadrilateral ABCD is a parallelogram in which  $\angle B$  measures  $74^\circ$ . Determine the measures of the other angles and state your reasons.

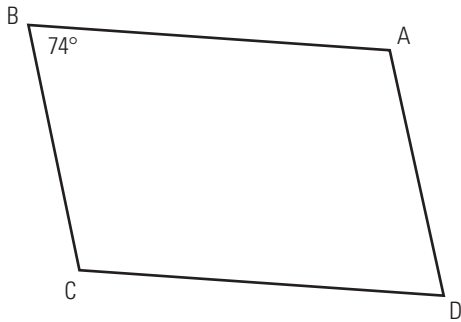

### Example 2

Given the diagram below, identify all the pairs of parallel lines and explain your selection.

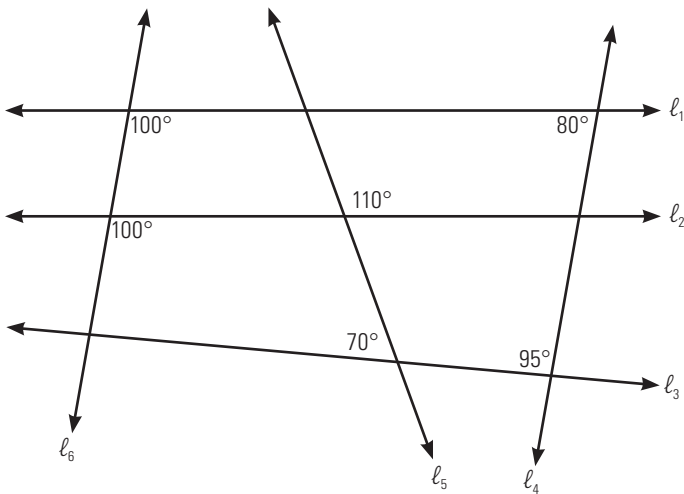

### SOLUTION

$l_6$  is parallel to  $l_4$ . If you consider  $l_1$  to be a transversal,  $100^\circ$  and  $80^\circ$  are interior angles on the same side of the transversal.

$l_1$  is parallel to  $l_2$ . If  $l_6$  is a transversal, the two  $100^\circ$  angles are corresponding angles.

### BUILD YOUR SKILLS

4. Find a pair of parallel lines in the following diagram. On the diagram, mark all the angles necessary to determine this.

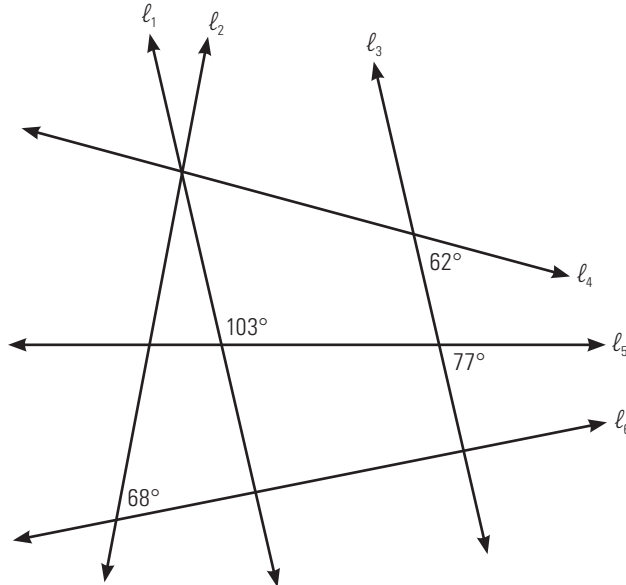

5. What size must  $\angle 1$  be if  $l_1$  is parallel to  $l_2$ ?

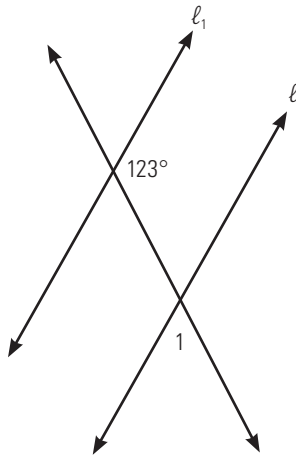

6. The two vertical pipes in the diagram need to be moved to be parallel to each other. By what angle must the plumber move the second pipe?

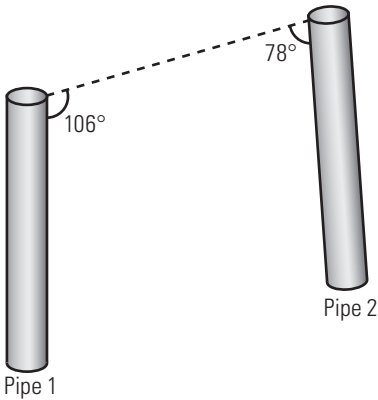

### Example 3

Given parallelogram ABCD, determine the values of  $\angle B$ ,  $\angle C$ , and  $\angle D$  in that order, stating your reason for each measure.

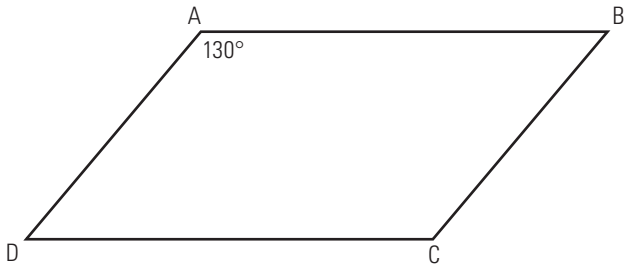

### SOLUTION

In a parallelogram, opposite sides are parallel.

AD is parallel to BC, and they are intersected by transversal AB.  $\angle B$  is an interior angle on the same side of the transversal as  $\angle A$ . Therefore, it is complementary to  $\angle A$ .

$$180^\circ - 130^\circ = 50^\circ$$

$\angle B$  is  $50^\circ$ .

You can use the notation  $AD \parallel BC$  to indicate that  $AD$  and  $BC$  are parallel.

$AB$  is parallel to  $DC$ , and they are intersected by transversal  $BC$ . You know that  $\angle B$  is  $50^\circ$ .  $\angle C$  is an interior angle on the same side of the transversal as  $\angle B$ , so they are complementary.  $\angle C$  measures  $130^\circ$ .

$AB$  is parallel to  $DC$ , and they are intersected by transversal  $AD$ . You know that  $\angle A$  measures  $130^\circ$  and is complementary to  $\angle D$ . Therefore,  $\angle D$  measures  $50^\circ$ .

### BUILD YOUR SKILLS

7. If  $l_1$  and  $l_2$  are parallel and are intersected by transversals  $t_1$  and  $t_2$ , what are the measures of the indicated angles? Solve for the measures in the given order, stating your reasoning.

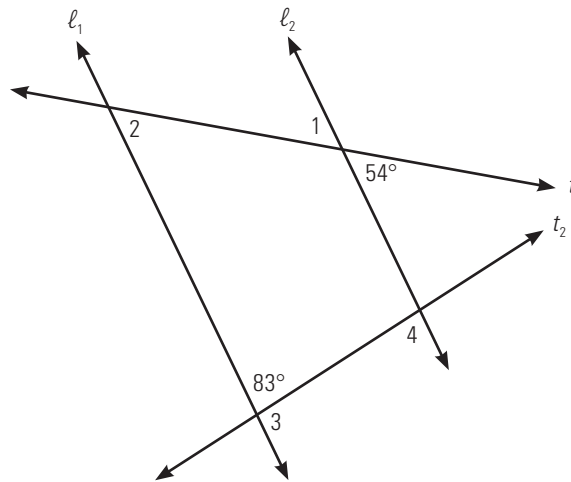

SOLVING ANGLE MEASURES	
Angle Measure	Reason
$\angle 1 =$	
$\angle 2 =$	
$\angle 3 =$	
$\angle 4 =$	

8. In the diagram below, if the side of the house and the side of the shed are parallel, what are the measures of  $\angle 1$  and  $\angle 2$ ?

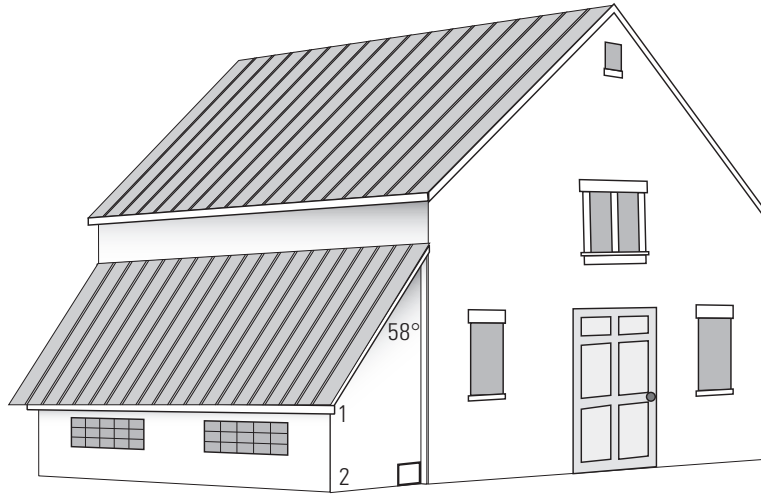

9. A plumber must install pipe 2 parallel to pipe 1. He knows that  $\angle 1$  is  $53^\circ$ . What is the measure of  $\angle 2$ ?

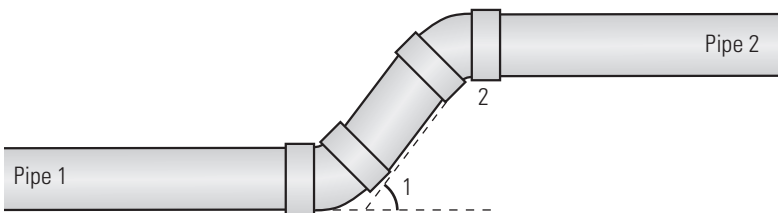

### PRACTISE YOUR NEW SKILLS

1. Given the diagram below, where  $l_1$  is parallel to  $l_2$ , find the measures of the indicated angles and state your reasons.

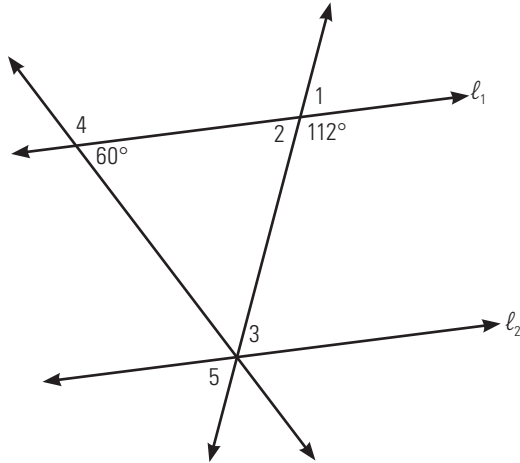

2. In the diagram below, the top of the bridge is parallel to the deck, and the brace in the middle is vertical, perpendicular to the deck, determine the size of  $\angle 1$  and  $\angle 2$ .

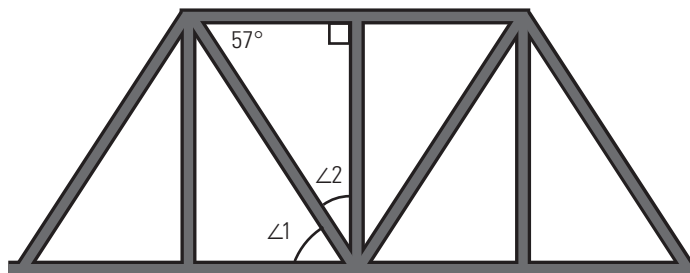

3. Identify the pairs of parallel lines in the following diagram. (Hint: The lines can be extended.)

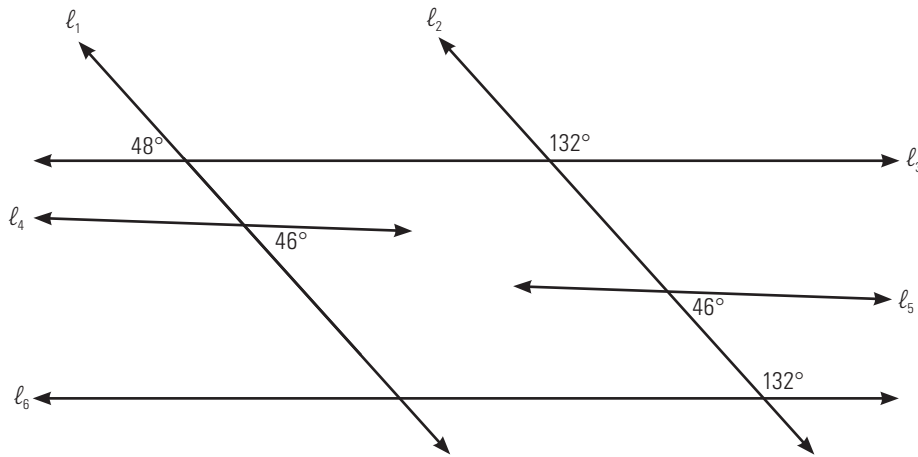

4. Examine the following diagram. By how many degrees do the studs need to be moved in order to be parallel to each other? What direction do they need to move in? (The studs are indicated by the capital letters.)

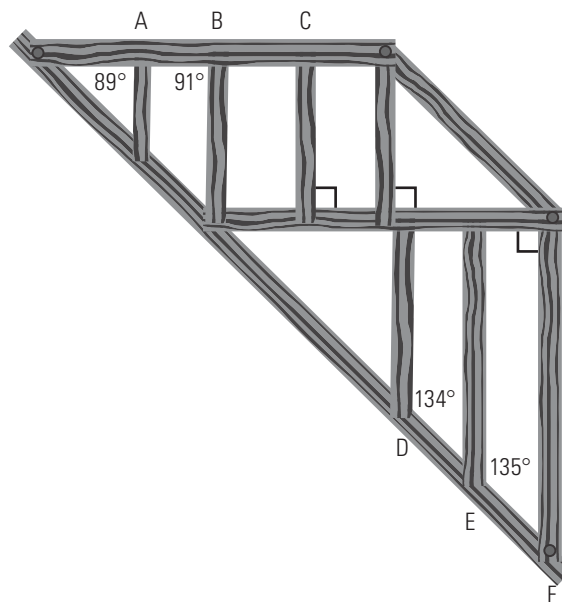



## CHAPTER TEST

1. Classify each of the following as acute, right, obtuse, straight, or reflex angles.

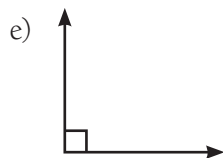
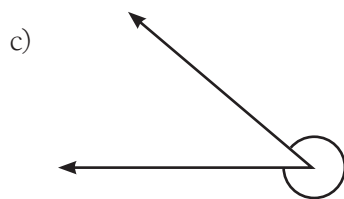
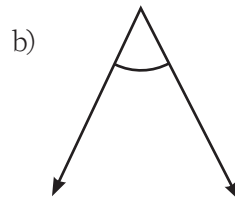

2. Fill in the missing parts in the table. If no such angle exists, explain why.

ANGLE CALCULATIONS			
Angle	Complement	Supplement	Resulting angle measure after the angle is bisected
58°			
			47°
		93°	
153°			
	25°		

3. Name the relationship between the indicated pairs of angles.

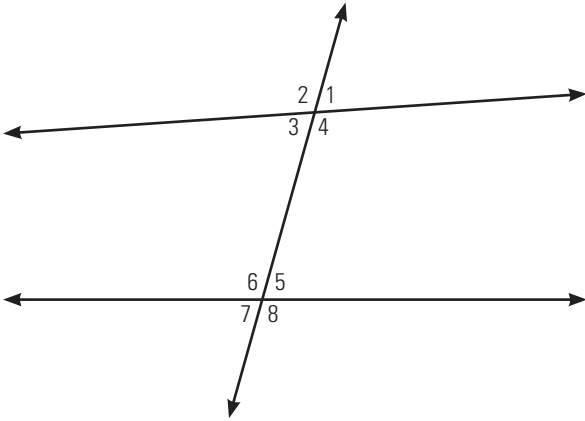

- a)  $\angle 3$  and  $\angle 5$
  - b)  $\angle 4$  and  $\angle 5$
  - c)  $\angle 1$  and  $\angle 3$
  - d)  $\angle 2$  and  $\angle 6$
4. In the diagram below,  $l_1$  is parallel to  $l_2$ . Determine the measures of the indicated angles and explain your reasons. Write the answers in the order that you calculated them.

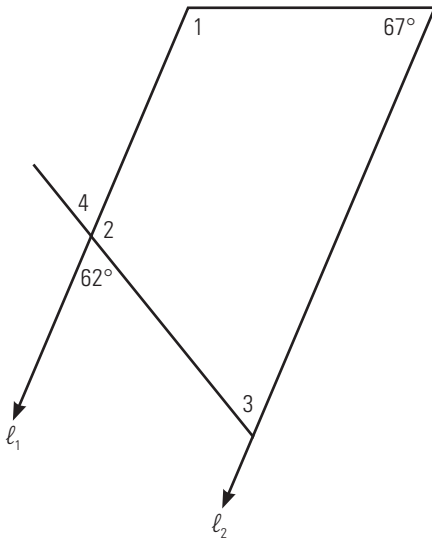

5. Given the following diagram, what must be the measures of  $\angle 1$  and  $\angle 2$  if  $BE$  is parallel to  $CD$ ? State your reasons.

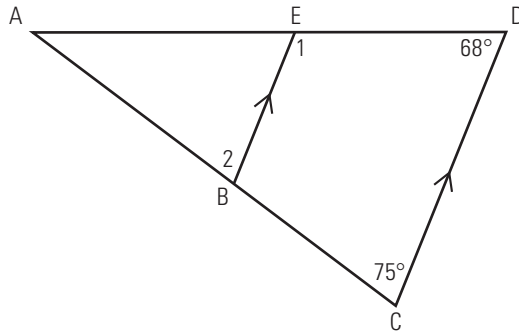

6. In trapezoid  $PQRS$ ,  $PS$  is parallel to  $QR$ . What are the measures of  $\angle 1$  and  $\angle 2$ ?

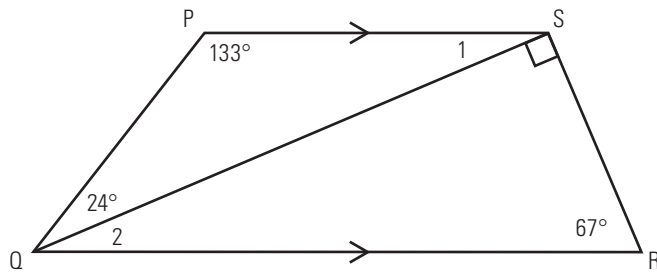

7. If  $l_1$  is parallel to  $l_2$ , and  $l_3$  is parallel to  $l_5$ , what are the following angle measures?

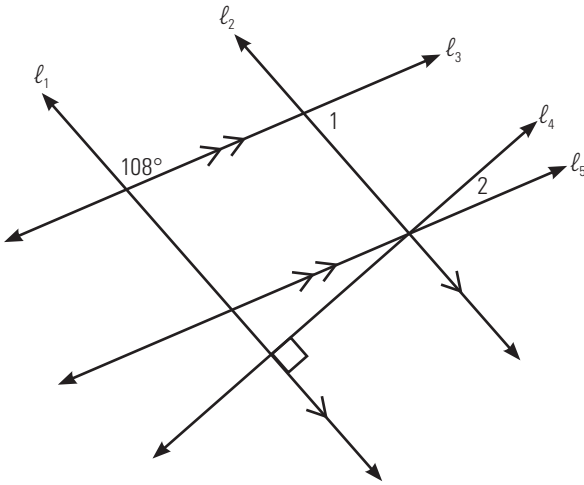

- a) the value of  $\angle 1$
- b) the value of  $\angle 2$  that will make  $l_4$  perpendicular to  $l_2$

8. On the map below, what is the true bearing from the following points?

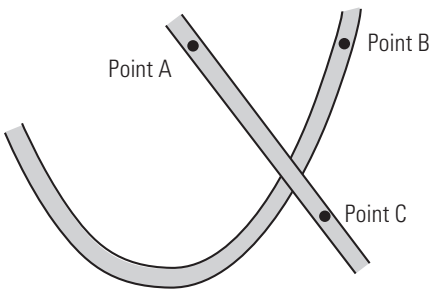

- a) A to B
- b) B to C

9. Fred states that if  $l_1$  is parallel to  $l_2$ , and  $l_2$  is parallel to  $l_3$ , then it follows that  $l_1$  is parallel to  $l_3$ . Is Fred right? Show your answer using a diagram.

10. In the diagram below,  $l_1$  is parallel to  $l_2$ , and  $l_2$  is parallel to  $l_3$ . State two angles whose measures are the same as  $\angle 7$ . Explain your reasoning.

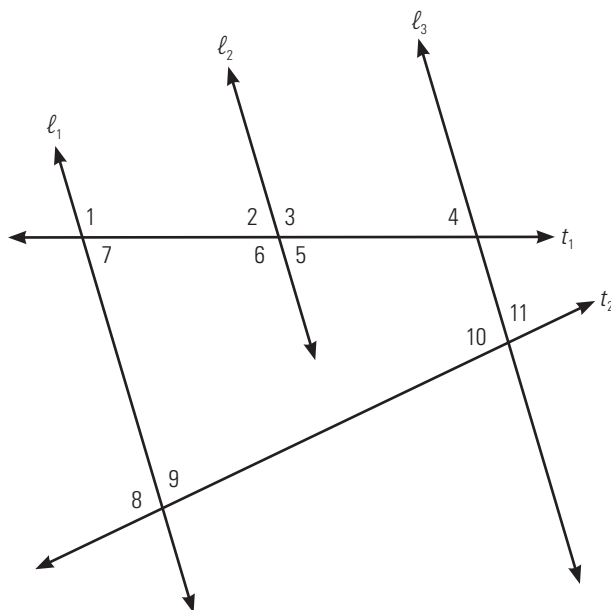

# Chapter 6

## Similarity of Figures



*These nesting toolboxes were designed to be similar figures.*

### Similar Polygons

## 6.1

#### **REVIEW: WORKING WITH RATIO, RATE, AND PROPORTIONAL REASONING**

In this chapter, you will apply ratio, rate, and proportional reasoning.

See chapter 1 of this workbook for a review of these concepts.

## NEW SKILLS: WORKING WITH SIMILAR FIGURES

Two figures are similar if they have the same shape but are different sizes. A diagram drawn to scale to another diagram creates a similar figure. Likewise, an enlargement of a photograph, when reproduced to scale, yields a similar figure.

For two figures to be similar:

**corresponding sides:**

two sides that occupy the same relative position in similar figures

- corresponding angles must be the same size; and
- **corresponding sides** must be in the same proportion.

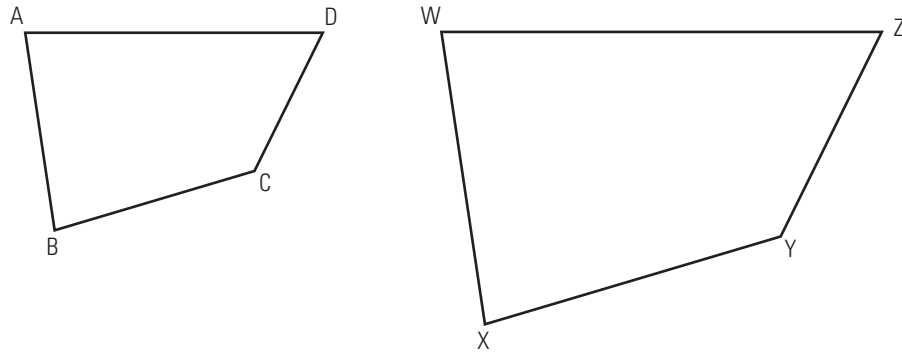

In quadrilateral ABCD and quadrilateral WXYZ, the following equivalencies are true.

$$\angle A = \angle W$$

$$\angle B = \angle X$$

$$\angle C = \angle Y$$

$$\angle D = \angle Z$$

$$\frac{AB}{WX} = \frac{BC}{XY} = \frac{YZ}{DC} = \frac{DA}{ZW}$$

The two quadrilaterals are similar. This can be written as  $ABCD \sim WXYZ$ .

For more details, see page 227 of *MathWorks 10*.

If two figures have the same size and shape, they are said to be congruent, or similar. Similarity is shown by the symbol  $\sim$ .

**Example 1**

Tara has drawn a scale diagram of her bedroom so that she can sketch different arrangements of her furniture. On her diagram, the walls have the following lengths:

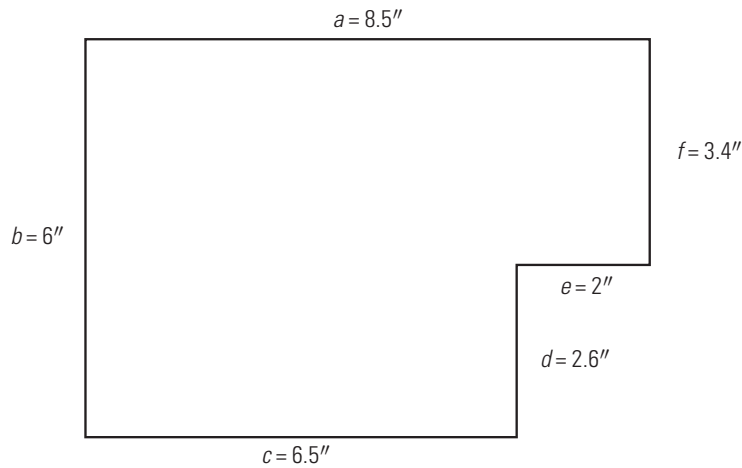

If the longest wall in her room is actually 12.75', how long are the other walls?

**SOLUTION**

Set up proportions between the longest wall and each of the other walls. Label the walls of the actual room with the same letters as those in the scale drawing, but use upper case letters. (For example, wall  $a$  is 8.5" on the drawing, and wall  $A$  is 12.75' in the actual room.)

Start with wall  $b$ .

$$\frac{a}{A} = \frac{b}{B}$$

$$\frac{8.5}{12.75} = \frac{6}{B}$$

Substitute the known values.

$$\frac{8.5}{12.75} = \frac{6}{B}$$

Work without units of measurement.

$$\cancel{12.75} \times B \times \frac{8.5}{\cancel{12.75}} = \frac{6}{\cancel{B}} \times \cancel{B} \times 12.75 \quad \text{Multiply by } 12.75B.$$

$$8.5B = 6 \times 12.75$$

$$8.5B = 76.5$$

$$\frac{8.5B}{8.5} = \frac{76.5}{8.5}$$

Divide to isolate  $B$ .

$$B = 9$$



Use the same method to solve the following proportions:

$$\frac{a}{A} = \frac{c}{C}$$

$$\frac{8.5}{12.75} = \frac{6.5}{C}$$

$$\frac{a}{A} = \frac{d}{D}$$

$$\frac{8.5}{12.75} = \frac{2.6}{D}$$

$$\frac{a}{A} = \frac{e}{E}$$

$$\frac{8.5}{12.75} = \frac{2}{E}$$

$$\frac{a}{A} = \frac{f}{F}$$

$$\frac{8.5}{12.75} = \frac{3.4}{F}$$

The lengths of the walls in Tara's bedroom are:

$$B = 9.0'$$

$$C = 9.75'$$

$$D = 3.9'$$

$$E = 3'$$

$$F = 5.1'$$

#### ALTERNATIVE SOLUTION

Determine the unit scale. If 8.5" represents 12.75', then calculate how many feet 1 inch represents.

$$12.75' \div 8.5 = 1.5'$$

The remaining side lengths can be calculated by multiplying each scaled unit by 1.5 ft per inch.

$$B = 6 \times 1.5$$

$$B = 9'$$

$$C = 6.5 \times 1.5$$

$$C = 9.75'$$

$$D = 2.6 \times 1.5$$

$$D = 3.9'$$

$$E = 2 \times 1.5$$

$$E = 3'$$

$$F = 3.4 \times 1.5$$

$$F = 5.1'$$

### BUILD YOUR SKILLS

1. The two figures shown below are similar. Find the lengths of the sides of the smaller figure. (The diagrams are not drawn to scale.)

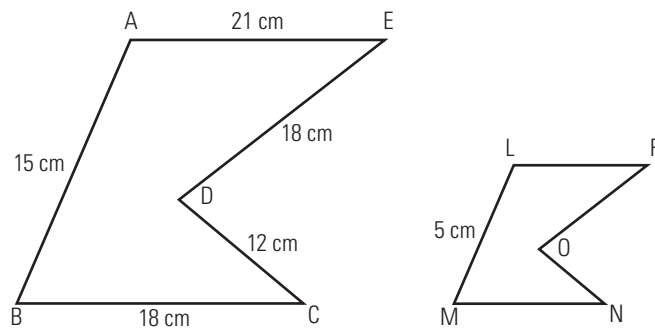

2. On a blueprint, a room measures 2.75 inches by 1.5 inches. If 1 inch represents 8 feet, what will be the dimensions of the room?

3. Identify the pairs of similar polygons below.

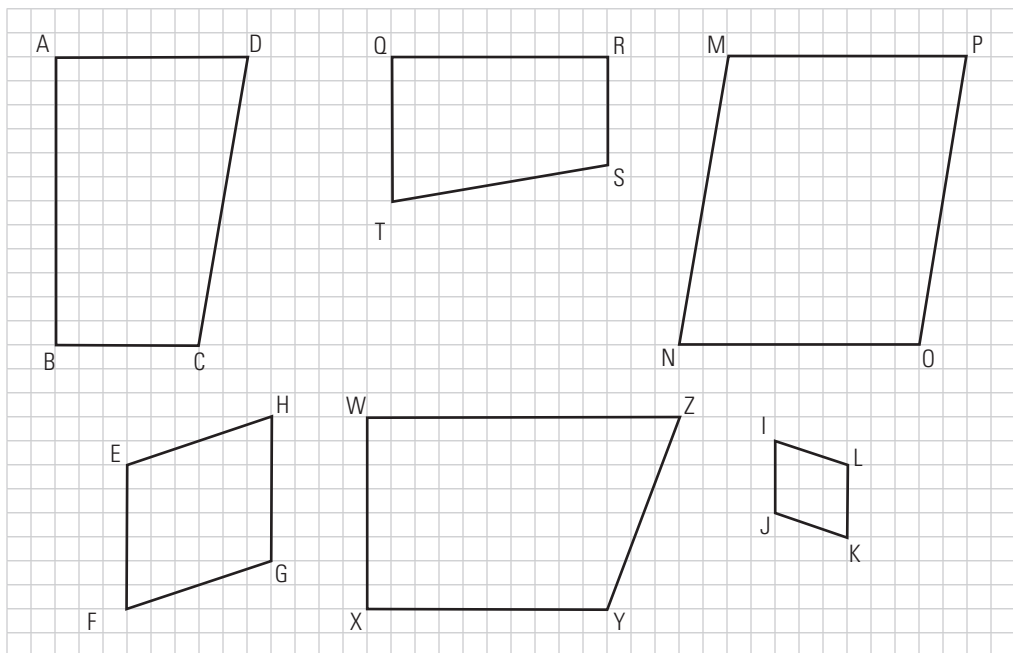

### Example 2

If  $\triangle RST$  is similar to  $\triangle LMN$  and angle measures of  $\triangle LMN$  are as follows, what are the angle measures of  $\triangle RST$ ?

$$\angle L = 85^\circ$$

$$\angle M = 78^\circ$$

$$\angle N = 17^\circ$$

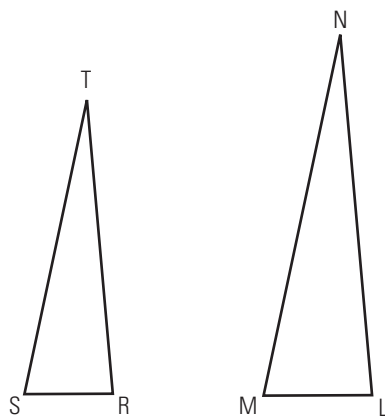

**SOLUTION**

Since the triangles are similar, corresponding angles must be equal.

$$\angle R = \angle L$$

$$\angle R = 85^\circ$$

$$\angle S = \angle M$$

$$\angle S = 78^\circ$$

$$\angle T = \angle N$$

$$\angle T = 17^\circ$$

Could you have answered this question without being given  $\angle N$ ? Explain your reasoning.

**BUILD YOUR SKILLS**

4. If two polygons ABCDEF and GHIJKL are similar, and the following angle measures are given, state the corresponding angles and their measures.

$$\angle J = 73^\circ$$

$$\angle B = 21^\circ$$

$$\angle K = 40^\circ$$

5. If  $\triangle ABC$  is similar to  $\triangle XYZ$  and the following angle measures are known, what are the values of the remaining angles?

$$\angle A = 32^\circ$$

$$\angle C = 48^\circ$$

$$\angle Y = 100^\circ$$

6. If trapezoid PQRS is similar to trapezoid LMNO, what are the values of  $w$ ,  $x$ ,  $y$ , and  $z$ ?

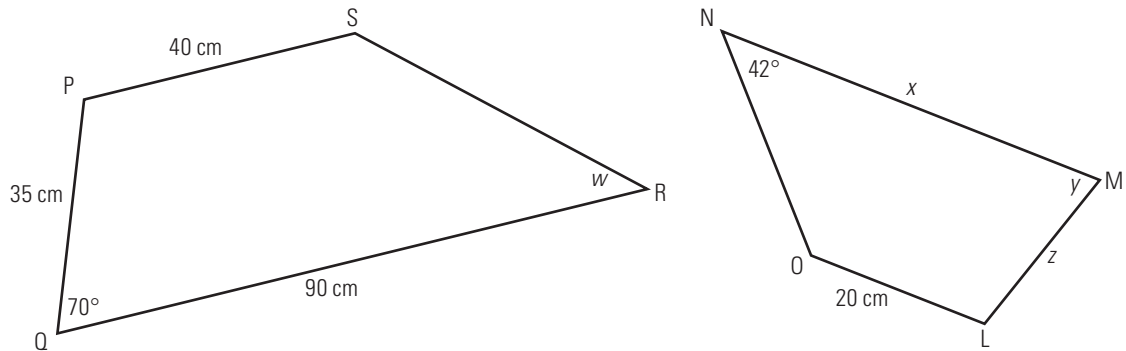

### Example 3

A true model must be mathematically similar in shape to the original.

Jason wants to build a model of his house. He will build the model using a scale where 5 cm represents 2 m. If one room is 6.5 m long, 4.8 m wide, and 2.8 m tall, what will its dimensions be in the model?

#### SOLUTION

Similarity can be applied to three-dimensional objects.

The ratio of the model to the actual room is 5 cm:2 m. Write this ratio without units as the fraction  $\frac{5}{2}$ .

Represent length, width, and height with  $\ell$ ,  $w$ , and  $h$ , respectively, and set up proportions to calculate their measures.

$$\frac{5}{2} = \frac{\ell}{6.5}$$

$$\frac{5}{2} = \frac{w}{4.8}$$

$$\frac{5}{2} = \frac{h}{2.8}$$

Solve for  $\ell$ .

$$\frac{5}{2} = \frac{\ell}{6.5}$$

Substitute the known values.

$$\cancel{2} \times 6.5 \times \frac{5}{\cancel{2}} = \frac{\ell}{\cancel{6.5}} \times \cancel{6.5} \times 2 \quad \text{Multiply by the two denominators.}$$

$$6.5 \times 5 = 2\ell$$

$$32.5 = 2\ell$$

Divide to isolate  $\ell$ .

$$\frac{32.5}{2} = \ell$$

$$16.25 = \ell$$

The length of the room in the model will be 16.25 cm.

Use the same method to solve for  $w$  and  $h$ .

$$\frac{5}{2} = \frac{w}{4.8}$$

$$12 = w$$

$$\frac{5}{2} = \frac{h}{2.8}$$

$$7 = h$$

The width in the model is 12 cm and the height is 7 cm.

## BUILD YOUR SKILLS

- Redo Example 3 by first determining a unit scale (the number of centimetres that represent 1 metre), then calculating length, width, and height for the model.

8. If a house is 40 feet long, 35 feet wide, and the top of the roof is 27 feet above ground level, what will the corresponding dimensions be of a model built so that 1 foot is represented by  $\frac{1}{2}$  inch?
9. Theresa folds origami paper to make stacked boxes. The outer box is 12 cm by 8 cm by 4 cm. Theresa would like to make three smaller, similar boxes, each scaled down by  $\frac{1}{4}$  of the previous box. What are the dimensions of the three smaller boxes?

**PRACTISE YOUR NEW SKILLS**

1. The scale of a model airplane to the actual airplane is 2:45. If the model is 38 centimetres long, how long is the actual airplane?





5. Marie-Claude has a series of four nested funnels in her kitchen that are similar to the one shown in the diagram. If the other three funnels have top diameters of 10 cm, 8 cm, and 6 cm, find the measures of the remaining parts for all three funnels.

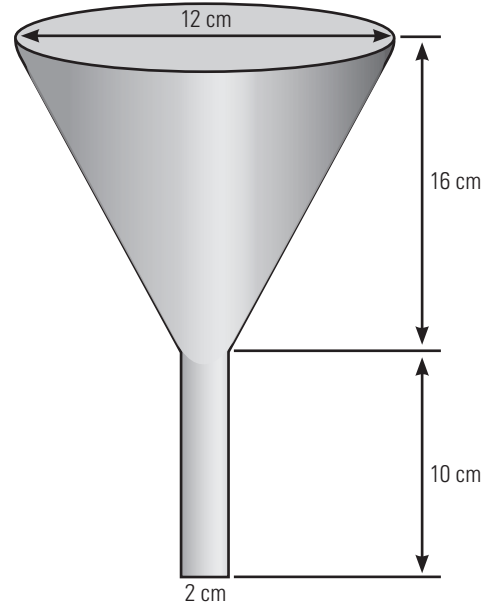

## Determining if Two Polygons Are Similar

# 6.2

### NEW SKILLS: WORKING WITH SIMILAR POLYGONS

In the last section, you considered two or more figures that were similar and found their corresponding sides and angles. How do you determine if two figures are similar, and what changes can you make to a given shape and keep it similar to the original?

#### Example 1

Are the two pentagons shown below similar? If so, explain how you know. If not, explain what you would need to know. (Angles marked with the same symbol are equal.)

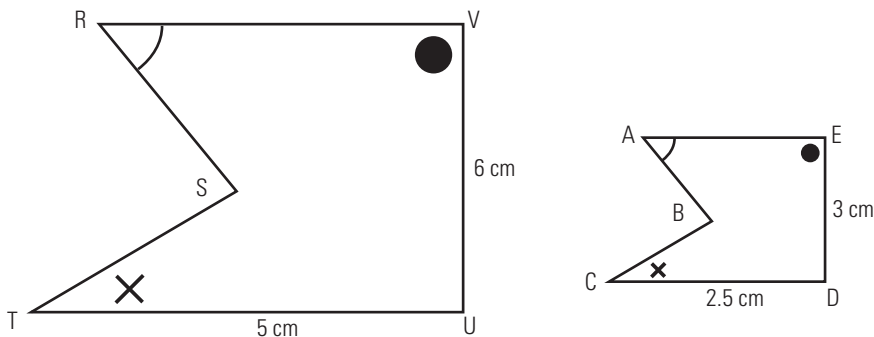

#### SOLUTION

You know that three angles of one pentagon are equal to the three corresponding angles of the second pentagon.

$$\angle R = \angle A$$

$$\angle T = \angle C$$

$$\angle V = \angle E$$

However, you cannot determine if the other two pairs of corresponding angles ( $\angle S$  and  $\angle B$ ,  $\angle U$  and  $\angle D$ ) are equal. Therefore, you cannot state for certain that the two pentagons are similar.

For more information, see page 239 of *MathWorks 10*.

Figures are similar if corresponding angles are equal and corresponding sides are proportional.



**Example 2**

Determine if the two given parallelograms, ABCD and WXYZ, are similar.

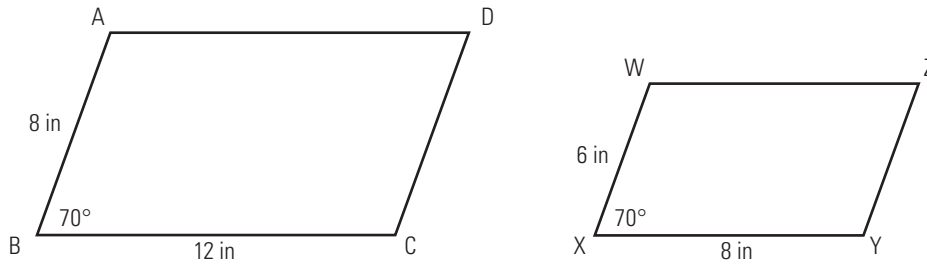
**SOLUTION**

In a parallelogram, opposite angles are always equal in measure.

$$\angle A = \angle C$$

$$\angle B = \angle D = 70^\circ$$

$$\angle X = \angle Z$$

$$\angle X = \angle Z = 70^\circ$$

Also, interior angles in a parallelogram always add up to  $360^\circ$ . Because the  $70^\circ$  angles in the two parallelograms correspond, the other angles must also correspond.

$$\angle A = \angle C = \angle W = \angle Y$$

Therefore, all corresponding angles are equal.

For the parallelograms to be similar, the sides would have to be proportional and the following would have to be true.

$$\frac{AB}{BC} = \frac{WX}{XY}$$

Calculate to determine if this is true.

$$\frac{AB}{BC} = \frac{8}{12}$$

$$\frac{AB}{BC} = \frac{8 \div 4}{12 \div 4}$$

$$\frac{AB}{BC} = \frac{2}{3}$$

$$\frac{WX}{XY} = \frac{6}{8}$$

$$\frac{WX}{XY} = \frac{6 \div 2}{8 \div 2}$$

$$\frac{WX}{XY} = \frac{3}{4}$$

$$\frac{2}{3} \uparrow \frac{3}{4}$$

The sides are not proportional, so the parallelograms are not similar.

### BUILD YOUR SKILLS

4. Janelle stated that increasing or decreasing the sides of a given figure by the same factor will always produce a figure similar to the original. Is this true? Give one example that illustrates your answer.
  
  
  
  
  
  
  
  
  
  
5. Aidan frames a 24-inch by 36-inch picture with a 4-inch frame. Is the framed picture similar in shape to the unframed picture? Show your calculations.

6. One cylinder has a radius of 25 cm and a height of 35 cm. Another cylinder has a radius of 30 cm and a height of 40 cm. Are the cylinders similar? Show your calculations.

**PRACTISE YOUR NEW SKILLS**

1. The scale on a map is 2.5 cm:500 m.
  - a) What distance is represented by a 12.5-cm segment on the map?
  
  
  
  
  
  
  
  
  
  
  - b) How long would a segment on the map be if it represented 1.5 km?
  
  
  
  
  
  
  
  
  
  
2. Show whether a rectangular prism that is 6 m by 10 m by 8 m is similar to one that is 4 m by 7 m by 5 m.

3. Colin states that the following two figures are similar, but Tai disagrees, saying that they don't have enough information. Who is right? Show your calculations.

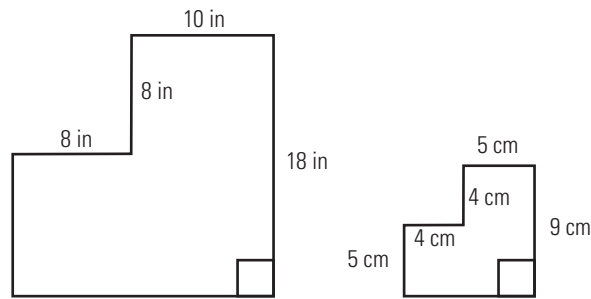

4. While he was at the pet food store, Jeremy saw three different sized dog mats. They measured 36 inches by 28 inches, 27 inches by 21 inches, and 24 inches by 18 inches. Are all the mats similar? Show your calculations.
5. Using two similar rectangles, show whether their areas are in the same proportion as the sides.

## Drawing Similar Polygons

# 6.3

### NEW SKILLS: WORKING WITH SCALE DIAGRAMS

Artists, architects, and planners use scale diagrams or models in their work. The diagrams or models should be in proportion to the actual objects so that others can visualize what the real objects look like.

In this section, you will practise drawing scale diagrams.

#### Example 1

Use graph paper to construct a figure similar to the one given, with sides that are  $1\frac{1}{2}$  times the length of the original. Explain how you know that the corresponding angles are equal.

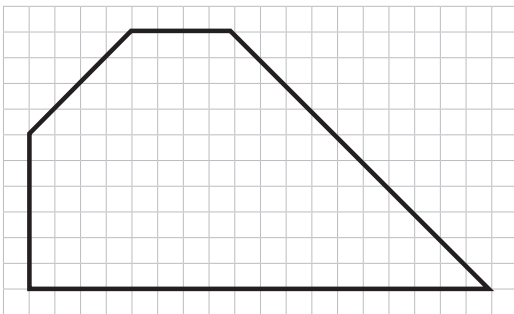

#### SOLUTION

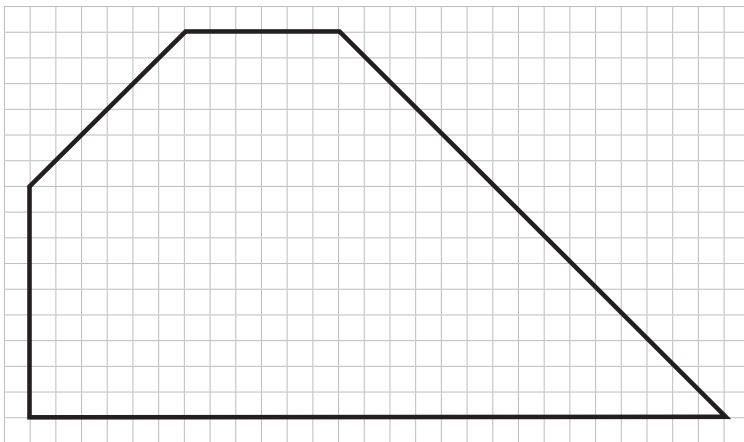

The sizes of the angles will not change by increasing the lengths of the sides, so the corresponding angles must be equal.

For more information, see pages 248–250 of *MathWorks 10*.





3. Bernie's house is 55 ft wide and 40 ft deep. A drawing of his property shows the house is 10 in wide and 7.3 in deep. What scale was used on the drawing?

### Example 2

Xavier is building a staircase using scale drawings. On the drawing, the height of one stair is 0.5 cm and the depth is 0.9 cm. Xavier will use a scale factor of 40 to build the stairs. Calculate the height and depth of the stairs he will build.

#### SOLUTION

A scale factor of 40 means that the actual measure is 40 times the measure on the drawing. This can be written as a ratio of 1:40 or  $\frac{1}{40}$ .

To calculate the height of one stair, set up a proportion.

$$\begin{aligned}\frac{0.5}{x} &= \frac{1}{40} \\ 40 \times \cancel{x} \times \frac{0.5}{\cancel{x}} &= \frac{1}{\cancel{40}} \times x \times \cancel{40} \\ 40 \times 0.5 &= x \\ 20 &= x\end{aligned}$$

The height of the stair will be 20 cm.

Use the same method to calculate the depth of the stair.

$$\begin{aligned}\frac{0.9}{x} &= \frac{1}{40} \\ 40 \times \cancel{x} \times \frac{0.9}{\cancel{x}} &= \frac{1}{\cancel{40}} \times x \times \cancel{40} \\ 40 \times 0.9 &= x \\ 36 &= x\end{aligned}$$

The depth of the stair will be 36 cm.

**BUILD YOUR SKILLS**

4. Simrin has built two end tables. The second table is a slightly larger version of the first. Given the dimensions below, calculate what scale factor Simrin used to make the larger table.

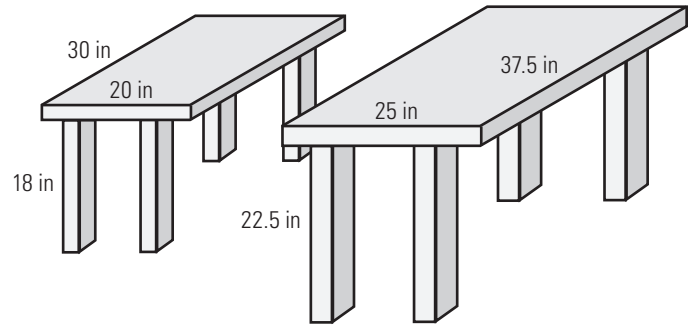

5. A craft store uses small gift boxes to wrap purchases. They have one box that is 20 cm by 12 cm by 5 cm. Another box is larger by a scale factor of 1.3. What are the dimensions of the larger box?

6. Hazuki made a kite with the dimensions shown below. She decided it would work better if it were bigger. If her new kite tail has a length of 49 cm, what scale factor did she use, and what are the kite's other dimensions?

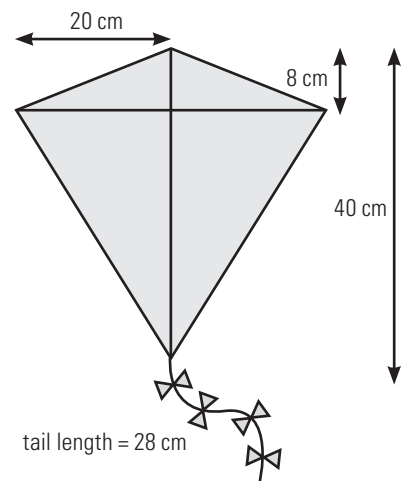

**PRACTISE YOUR NEW SKILLS**

1. The scale ratio (model:original) between two diagrams is 3:5. If one measure on the model is 45 mm, what was the measure on the original?
  
2. Draw a square with sides of 2 cm, and a second square with sides that are 3 cm.
  - a) Is the second square similar to the first? Explain your reasoning.
  
  - b) If you draw a rectangle whose sides are 5 cm and 8 cm, and a second rectangle with sides that are 3 cm longer, will the two be similar? Explain your reasoning.
  
3. Draw a rectangular prism similar to the one shown below with sides that are  $\frac{1}{2}$  the length of the original.

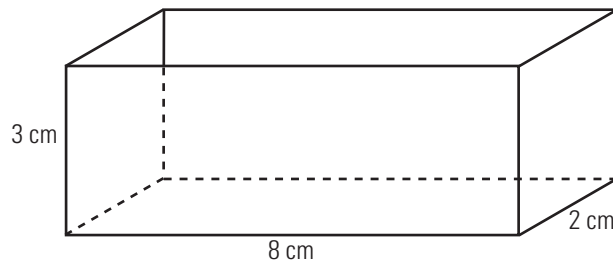

4. A poster shows a photograph of a cruise ship. The actual ship is 310 metres long. In the photograph, the cruise ship is 1.2 m long.
- a) What is the scale factor (to 4 decimal places)?
- b) A person 1.8 m tall was standing on the deck of the cruise ship when the photo was taken. How tall is the person on the photo (to the nearest tenth of a centimetre)?
5. A sporting goods store has miniature versions of tents on display. A six-person tent is 12' long by 10' wide. The miniature version has a length of  $1\frac{1}{2}$ .
- a) What is the width of the miniature version?
- b) What is the scale ratio (miniature:actual)?

## Similar Triangles

## 6.4

**NEW SKILLS: WORKING WITH SIMILAR TRIANGLES**

Similar triangles are very useful in making calculations and determining measurements.

The sum of the angles of a triangle is always  $180^\circ$ . If two corresponding angles in two triangles are equal, the third angles will also be equal.

Two triangles are similar if any two of the three corresponding angles are congruent, or one pair of corresponding angles is congruent and the corresponding sides adjacent to the angles are proportional.

Two right triangles are similar if one pair of corresponding acute angles is congruent.

**Example 1**

Given the two triangles below, find the length of  $n$ .

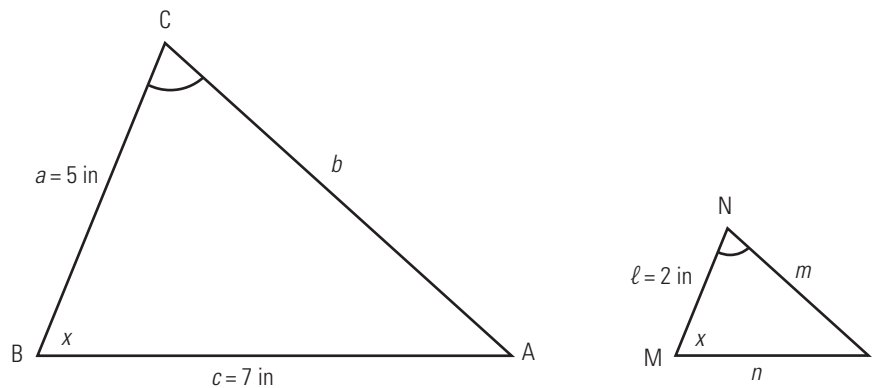
**SOLUTION**

You know that two of the three corresponding angles are congruent.

$$\angle C = \angle N$$

$$\angle B = \angle M$$

This means that  $\triangle ABC$  is similar to  $\triangle LMN$ .

To solve for  $n$ , set up a proportion.

$$\frac{n}{c} = \frac{\ell}{a}$$

$$\frac{n}{7} = \frac{2}{5}$$

$$5 \times \cancel{7} \times \frac{n}{\cancel{7}} = \frac{2}{\cancel{5}} \times 7 \times \cancel{5}$$

$$5n = 7 \times 2$$

$$5n = 14$$

$$n = \frac{14}{5}$$

$$n = 2.8$$

Side  $n$  is 2.8 in long.

For more information, see pages 257–258 of *MathWorks 10*.

### BUILD YOUR SKILLS

1. In each of the diagrams below,  $\triangle ABC$  is similar to  $\triangle XYZ$ . Find the length of the indicated side (to one decimal place).

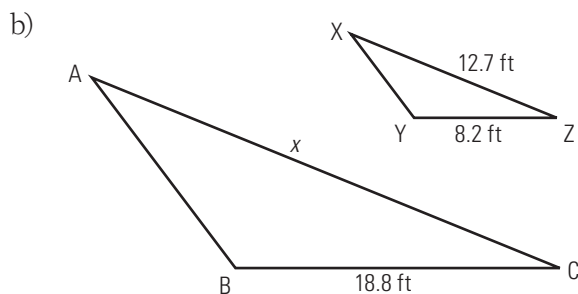
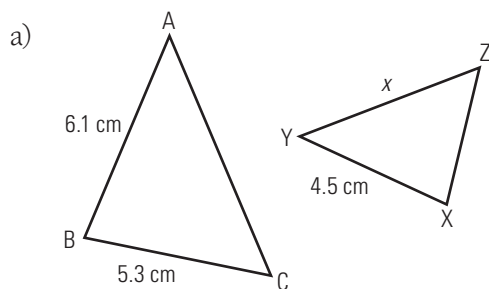

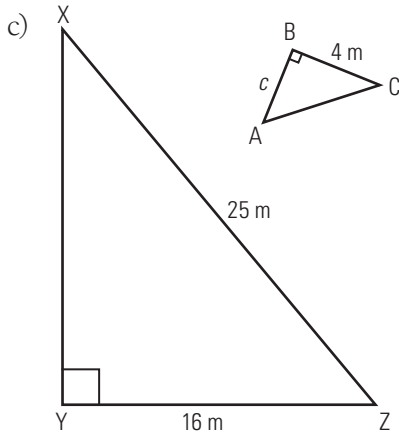

2. Given that  $\triangle ABC$  is similar to  $\triangle RST$ ,  $AB$  is 6 cm long,  $BC$  is 5 cm long, and  $RS$  is 8 cm long, find the length of a second side in  $\triangle RST$ . Can you find the length of the third side? Explain your answer.

3. Carmen thinks that any two isosceles triangles will be similar. Use examples to prove or disprove her belief.

An isosceles triangle has two sides equal in length, and two angles of equal measure.



**Example 2**

Ravi notices that a 2-m pole casts a shadow of 5 m, and a second pole casts a shadow of 9.4 m. How tall is the second pole?

**SOLUTION**

Sketch the situation.

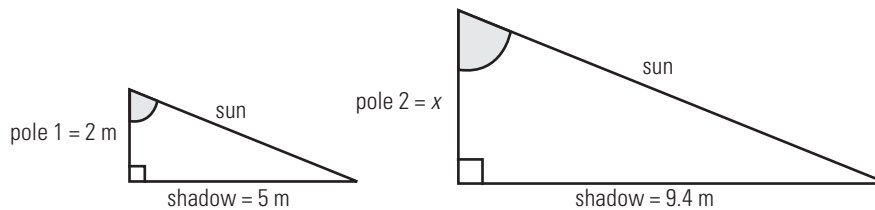

The angle between the rays of the sun and the pole is the same in both cases, so the two triangles are similar.

Set up a proportion to solve for the height of the second pole.

$$\frac{\text{height of pole 1}}{\text{shadow 1}} = \frac{\text{height of pole 2}}{\text{shadow 2}}$$

$$\frac{2}{5} = \frac{x}{9.4}$$

$$\cancel{9.4} \times 9.4 \times \frac{2}{\cancel{9.4}} = \frac{x}{\cancel{9.4}} \times \cancel{9.4} \times 5$$

$$9.4 \times 2 = 5x$$

$$18.8 = 5x$$

$$3.8 \approx x$$

The second pole is approximately 3.8 m tall.

**BUILD YOUR SKILLS**

4. Assuming that the slope of a hill is constant, and that a point 100 metres along the surface of the hill is 4.2 metres higher than the starting point, how high will you be if you walk 250 metres along the slope of the hill?
5. Maryam is sewing a patchwork quilt. The sketch she has drawn is to a scale of 1:8. Part of the design consists of right triangles that have legs that are 2.2 cm and 4.6 cm long. What will the lengths of the legs of the triangles in the finished quilt be?
6. Which of the following triangles are similar?

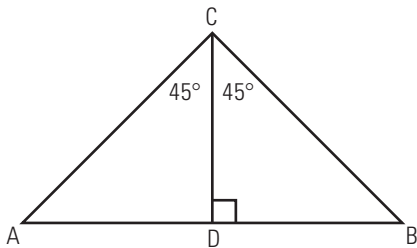

### PRACTISE YOUR NEW SKILLS

1. In the following diagram,  $AB$  is parallel to  $ED$ ,  $AB$  is 8 m,  $AC$  is 12 m, and  $CE$  is 7 m. Calculate  $ED$  to one decimal place.

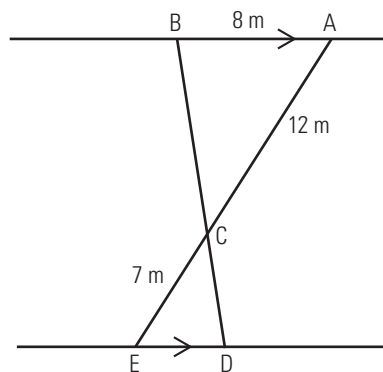

2. Madge has cut out two triangular shapes from a block of wood, as shown below. She says that the two shapes are similar. Is she correct? Show your calculations.

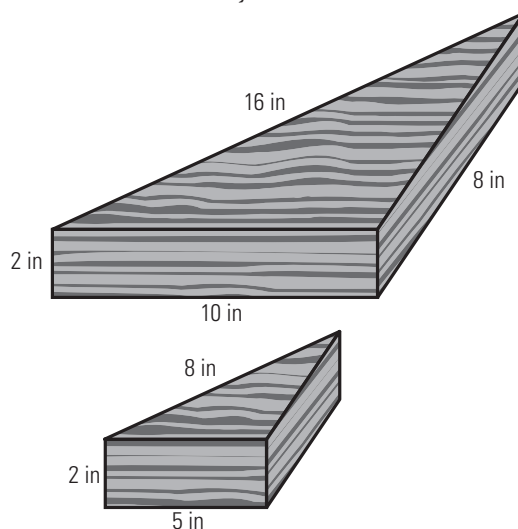

3. Given that  $\triangle FGH \sim \triangle XYZ$ , state which angles are equal and which sides are proportional.

4. Julian is visiting the Manitoba Legislative Building in Winnipeg, where he sees the statue of Louis Riel. Use the information in the diagram to find the height of the statue. Round your answer to a whole number.

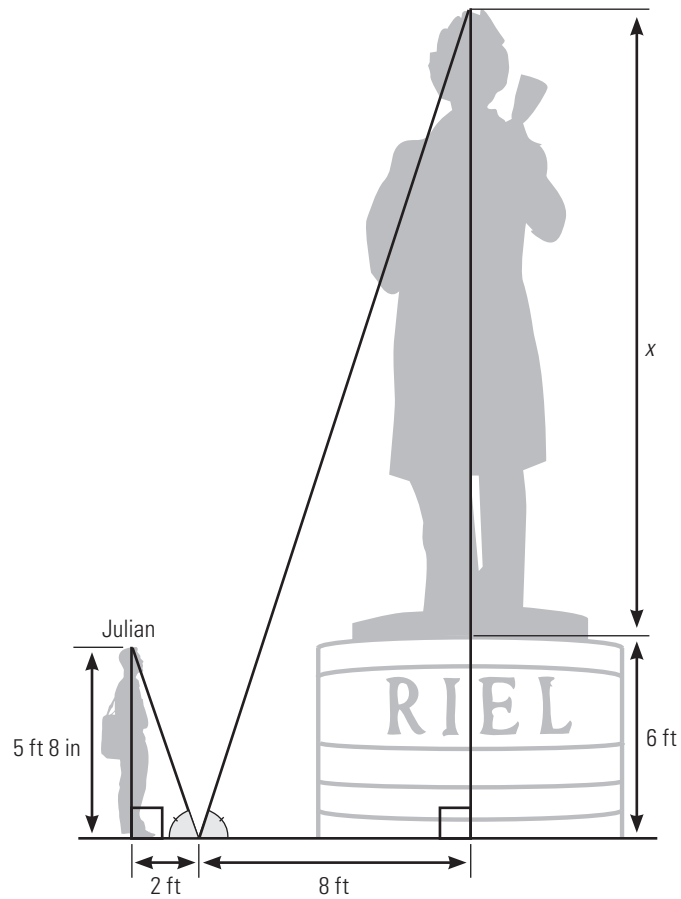

## CHAPTER TEST

1. The lengths of the sides of a pentagon are 2", 6", 10", 14", and 24". Calculate the lengths of the sides of a similar pentagon if the shortest side is 5".

2. Given that the two figures shown are similar, determine the values of  $x$  and  $y$ .

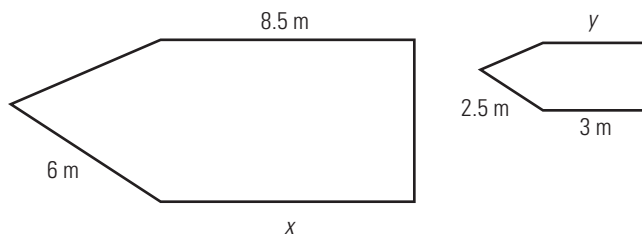

3. To determine the distance across a river (distance  $AB$ ), Lila took the following measurements. Assuming the two triangles in the diagram are similar, how wide is the river?

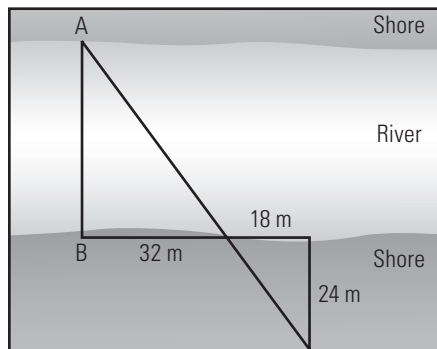

4. If a man casts a shadow that is 3.8 m long at the same time that an 8-m flagpole casts a shadow that is 15 m long, how tall is the man?

5. How does doubling the lengths of the sides of a rectangle to form a similar rectangle affect the area?

6. Amin cut out two blocks of wood as indicated. Are the two blocks similar in shape? Round your final calculations to two decimal places.

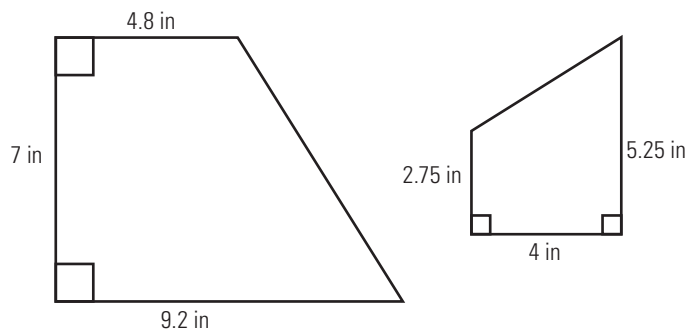



9. Young-Mee draws a sketch of her new office space to envision different furniture and equipment placements. On her drawing, the main area is 6" wide. What are the other dimensions of the drawing, given the measurements of the actual space shown in the diagram?

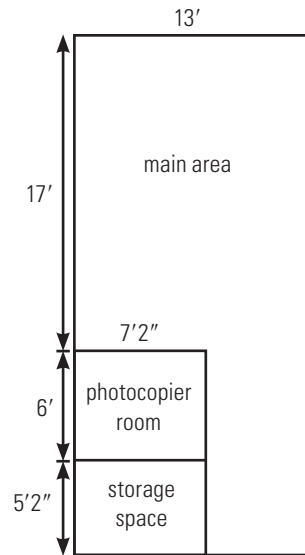

10. François is commissioned to paint a portrait based on a photograph. The photograph is 5" by 7", and the painting must be enlarged by a factor of 6.25. What are the dimensions of the painting?
11. Joanne knitted a blanket that measures 174 cm by 230 cm. Her sister asked Joanne to make a matching one for her son. If Joanne wants to make a similar blanket using a scale factor of 0.55, what will its dimensions be?



# Chapter 7

---

## Trigonometry of Right Triangles



*This man is installing an angle brace. By incorporating right triangles, angle braces provide support and strength to bookshelves, building roofs, and beyond.*

### 7.1

## The Pythagorean Theorem

---

### REVIEW: WORKING WITH TRIANGLES

---

Each vertex of a triangle is labelled with an upper case letter, and each side is labelled either with the lower case letter corresponding to the opposite vertex or with the upper case letters of the vertices it connects.

**Example 1**

Consider  $\triangle RST$ .

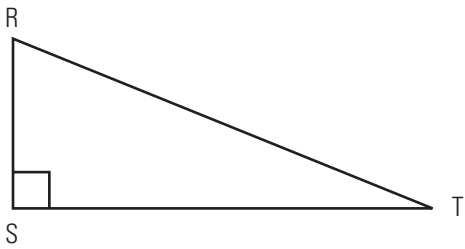

- Label the sides with the appropriate lower case letter.
- Name the sides using the upper case letters of the vertices they connect.

**SOLUTION**

- Each side is labelled with the lower case letter corresponding to the opposite vertex.

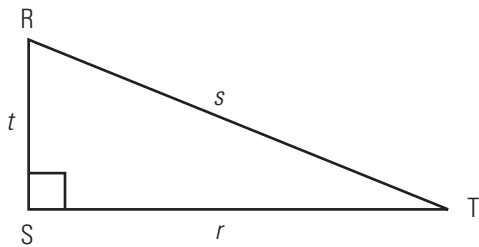

- The sides can also be named according to the upper case letters of the vertices they connect.

Side  $r$  can be called side  $ST$ .

Side  $s$  can be called side  $TR$ .

Side  $t$  can be called side  $RS$ .

## BUILD YOUR SKILLS

1. Label each side of the triangles below using a single lower case letter corresponding to the opposite vertex.

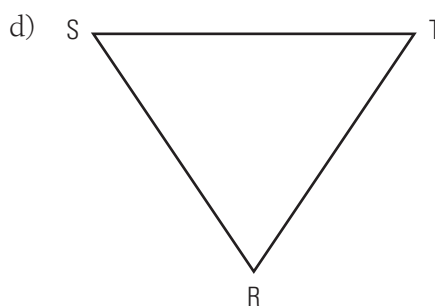
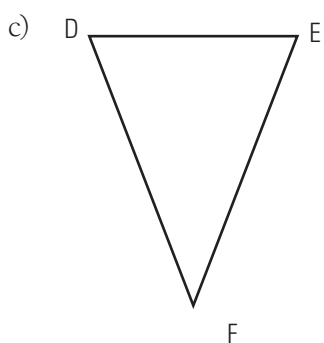
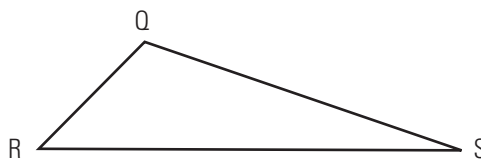
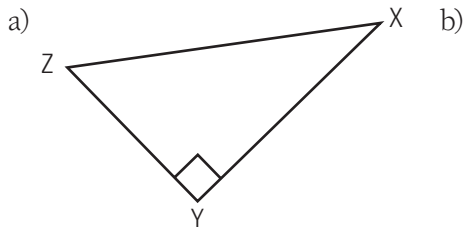

2. Label each vertex of the triangles below using a single upper case letter corresponding to the opposite side.

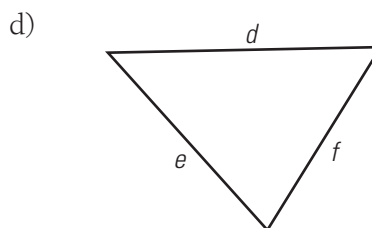
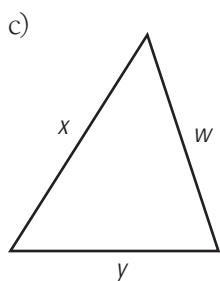
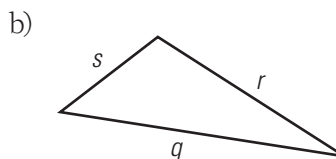
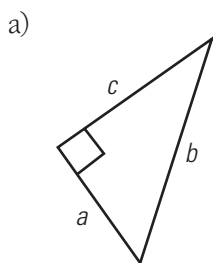

## NEW SKILLS: WORKING WITH THE PYTHAGOREAN THEOREM

A right triangle is a triangle with one right angle. The side opposite the right angle is the longest side and is called the **hypotenuse**. The other two sides are called legs (or, in some cases, arms).

The **Pythagorean theorem** states the relationship among the sides of a right triangle. Given a right triangle ABC with right angle C, the Pythagorean theorem states the following.

$$a^2 + b^2 = c^2$$

For more details, see page 272 of *MathWorks 10*.

**hypotenuse:** the longest side of a right triangle, opposite the  $90^\circ$  angle

**Pythagorean theorem:** in a right triangle, the sum of the squares of the lengths of the legs is equal to the square of the length of the hypotenuse

### Example 2

Label the sides of the triangles and state the Pythagorean theorem as it applies to them.

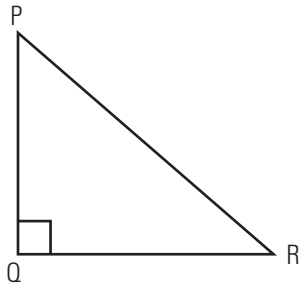

### SOLUTION

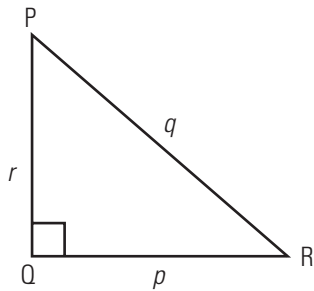

Since  $q$  is the hypotenuse, the Pythagorean theorem is written as follows.

$$p^2 + r^2 = q^2$$

**BUILD YOUR SKILLS**

3. Given the following diagram, use the lettering provided to state three Pythagorean relations that apply.

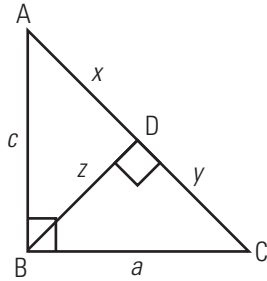

4. A ladder,  $\ell$ , is placed against the side of a house,  $h$ . The foot of the ladder is a distance  $d$  from the base of the house. Draw a diagram and express the relationship that exists between  $\ell$ ,  $h$ , and  $d$ .

5. Rearrange the Pythagorean theorem to solve first for  $x$  and then for  $y$ .

$$x^2 + y^2 = z^2$$

**Example 3**

Use the Pythagorean theorem to find the lengths of the missing sides of the triangles to the nearest tenth of a unit.

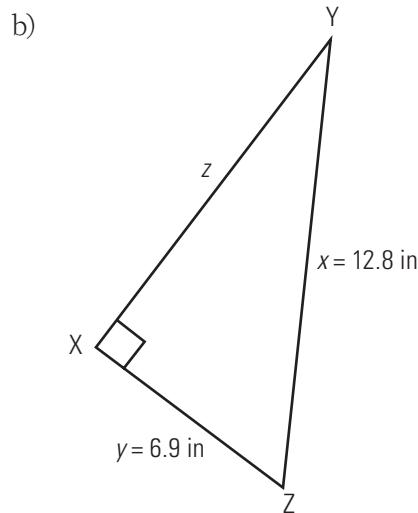
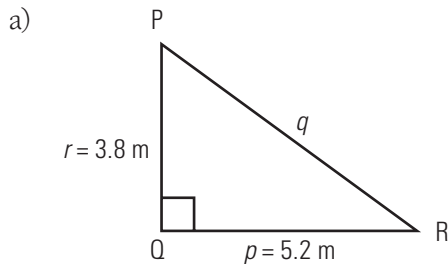
**SOLUTION**

- a) Write the Pythagorean theorem using the labels on the given triangle.

$$p^2 + r^2 = q^2$$

$$5.2^2 + 3.8^2 = q^2 \quad \text{Substitute the known values.}$$

$$27.04 + 14.44 = q^2$$

$$41.48 = q^2$$

$$\sqrt{41.48} = q \quad \text{Take the square root of both sides.}$$

$$6.44 \approx q$$

Side  $q$  is approximately 6.4 m.

- b) Write the Pythagorean theorem using the labels on the given triangle.

$$y^2 + z^2 = x^2$$

$$6.9^2 + z^2 = 12.8^2 \quad \text{Substitute the known values.}$$

$$47.61 + z^2 = 163.84$$

$$z^2 = 163.84 - 47.61 \quad \text{Subtract 47.61 from both sides to isolate } z.$$

$$z^2 = 116.23$$

$$z = \sqrt{116.23} \quad \text{Take the square root of both sides.}$$

$$z \approx 10.78$$

Side  $z$  is approximately 10.8 inches.

**BUILD YOUR SKILLS**

6. Calculate the values of  $x$  and  $y$ .

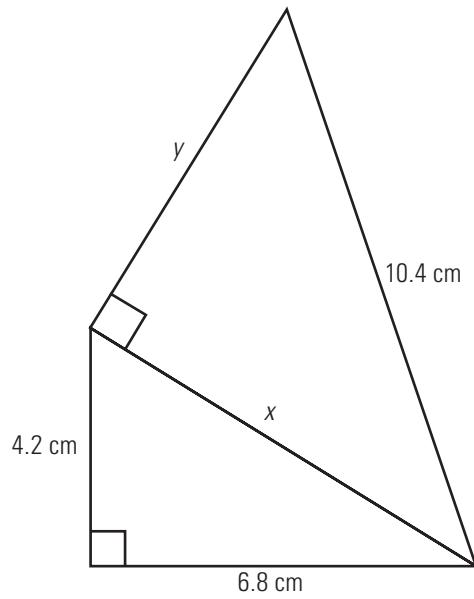

7. A 40-foot ladder reaches 38 feet up the side of a house. How far from the base of the house is the foot of the ladder?

8. A field is 120 m by 180 m. How much shorter is your route if you walk diagonally across the field rather than walking around the edge to the opposite corner?

**PRACTISE YOUR NEW SKILLS**

1. A stairway rises 6 feet 4 inches over a horizontal distance of 8 feet 6 inches. What is the diagonal length of the stairway?
2. A 28-metre long guy wire is attached to a point 24 m up the side of a tower. How far from the base of the tower is the guy wire attached?





## The Sine Ratio

## 7.2

## NEW SKILLS: WORKING WITH THE SINE RATIO TO SOLVE TRIANGLES

In chapter 6, you worked with similar triangles to discover that, in triangles with congruent angles, the ratio between the corresponding sides of the similar triangles is the same.

The following diagram shows similar triangles.  $\triangle ABC \sim \triangle XYZ$ .

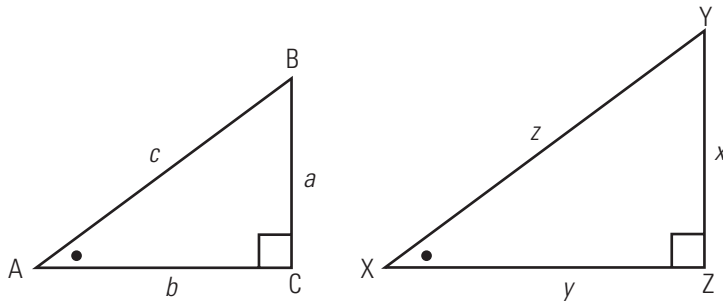

The ratios between corresponding sides are equal, so we know that the following is true.

$$\frac{a}{x} = \frac{c}{z}$$

This proportion can be rearranged so that each side of the equation represents a ratio of sides from the same triangle.

$$\cancel{x} \times z \times \frac{a}{\cancel{x}} = \frac{c}{\cancel{z}} \times \cancel{z} \times x \quad \text{Multiply both sides by the product of the denominators and simplify.}$$

$$za = cx$$

$$\frac{\cancel{z}a}{c\cancel{z}} = \frac{\cancel{z}x}{\cancel{z}z} \quad \text{Divide both sides by the same number and simplify.}$$

$$\frac{a}{c} = \frac{x}{z}$$

When triangles are similar, the ratio of the length of the side opposite a given angle to the length of the hypotenuse is always the same. This ratio is referred to as the **sine ratio**.

Given any right triangle with acute angle A, the sine ratio can be written as follows.

$$\text{sine } \angle A = \frac{\text{length of side opposite } \angle A}{\text{length of hypotenuse}}$$

The ratio is abbreviated as follows.

$$\sin A = \frac{\text{opp}}{\text{hyp}}$$

For more details, see page 283 of *MathWorks 10*.

Angles marked with the same symbol are equal.

**sine ratio:** in a right triangle, the ratio of the length of the side opposite a given angle to the length of the hypotenuse (abbreviated as sin)

Use your scientific calculator to calculate the values of the sines of angles.



3. Use your calculator to determine the value of  $\sin 90^\circ$ . Suggest a reason why this is so.

### Example 2

The sine ratio can be used to help you find missing parts of a right triangle.

A ladder 8.5 metres long makes an angle of  $72^\circ$  with the ground. How far up the side of a building will it reach?

#### SOLUTION

Sketch a diagram.

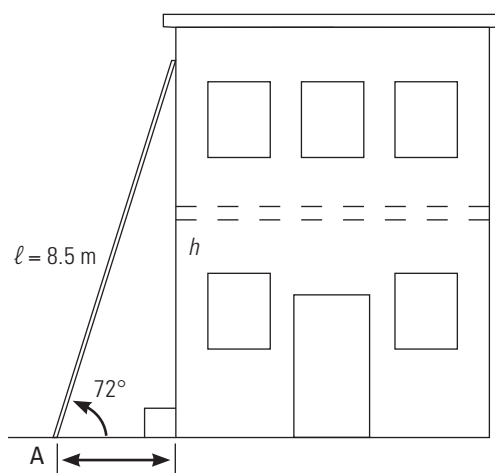

The height,  $h$ , is opposite the  $72^\circ$  angle, and the ladder,  $l$ , forms the hypotenuse of the triangle. A right triangle is formed, with  $h$  as the side opposite the  $72^\circ$  angle, and  $l$  as the hypotenuse.

Use the sine ratio to calculate  $h$ .

$$\sin A = \frac{\text{opp}}{\text{hyp}}$$

$$\sin 72^\circ = \frac{h}{8.5} \quad \text{Substitute the known values.}$$

$$8.5 \times \sin 72^\circ = \frac{h}{8.5} \times 8.5 \quad \text{Multiply both sides by 8.5.}$$

$$8.5 \times \sin 72^\circ = h$$

$$8.1 \approx h$$

The ladder reaches approximately 8.1 metres up the side of the building.

**BUILD YOUR SKILLS**

4. Calculate the length of the side opposite the indicated angle in the following diagrams.

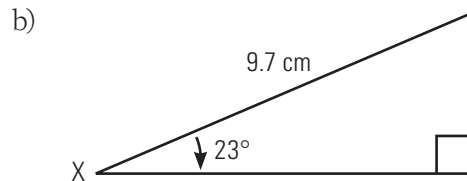
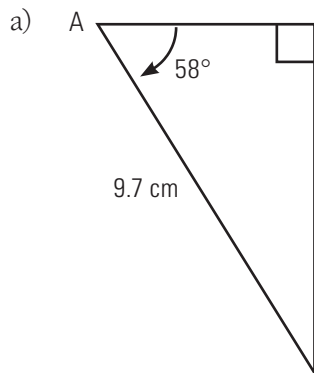

5. A rafter makes an angle of  $28^\circ$  with the horizontal. If the rafter is 15 feet long, what is the height at the rafter's peak?

6. How high is a weather balloon tied to the ground if it is attached to a 15-metre string and the angle between the string and the ground is  $35^\circ$ ?

### Example 3

Brad is building a ramp. The ramp must form an angle of  $22^\circ$  with the level ground and reach a point that is 1.5 metres above the ground. How long will the ramp be?

#### SOLUTION

Sketch a diagram.

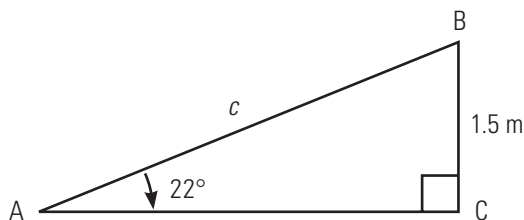

Let  $c$  represent the length of the ramp. On the diagram, 1.5 metres is opposite the  $22^\circ$  angle.

Use the sine ratio to solve for  $c$ .

$$\sin A = \frac{\text{opp}}{\text{hyp}}$$

$$\sin 22^\circ = \frac{1.5}{c} \quad \text{Substitute the known values.}$$

$$c \times \sin 22^\circ = \frac{1.5}{c} \times c \quad \text{Multiply both sides by } c.$$

$$c \times \sin 22^\circ = 1.5 \quad \text{Simplify.}$$

$$\frac{c \times \sin 22^\circ}{\sin 22^\circ} = \frac{1.5}{\sin 22^\circ} \quad \text{Divide both sides by } \sin 22^\circ \text{ to isolate } c.$$

$$c = \frac{1.5}{\sin 22^\circ}$$

$$c \approx 4.004$$

The ramp is approximately 4 metres long.

Wait until you have isolated the unknown variable before doing the calculation. This will minimize errors due to rounding.

**BUILD YOUR SKILLS**

7. Find the length of the hypotenuse in the following diagrams.

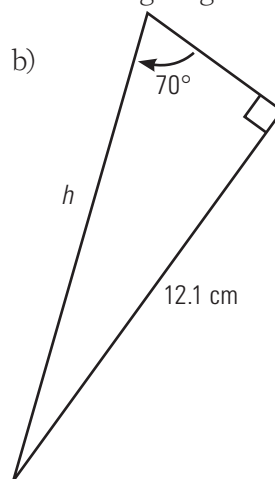
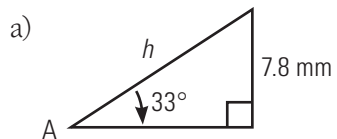

8. How long is a guy wire that is attached 4.2 metres up a pole if it makes an angle of  $52^\circ$  with the ground?

9. A boat is carried with the current at an angle of  $43^\circ$  to the shore. If the river is approximately 15 metres wide, how far does the boat travel before reaching the opposite shore?

### NEW SKILLS: WORKING WITH ANGLE OF ELEVATION AND DEPRESSION

When you look up at an airplane flying overhead, the angle between the horizontal and your line of sight is called an **angle of elevation**. When you look down from a cliff to a boat passing by, the angle between the horizontal and your line of sight is called an **angle of depression**.

For more details, see pages 288–289 of *MathWorks 10*.

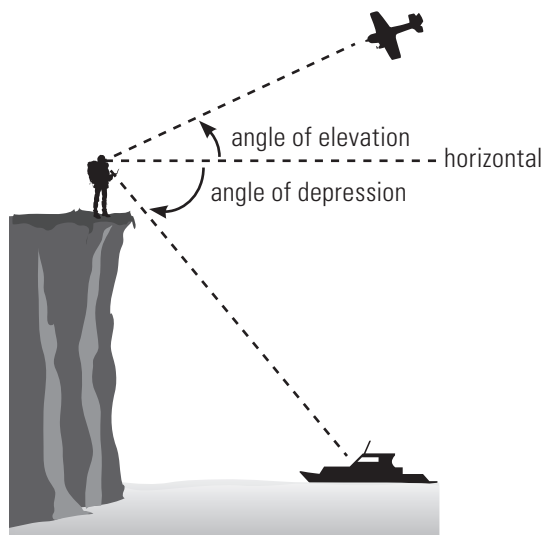

**angle of elevation:** the angle formed between the horizontal and the line of sight while looking upward; sometimes referred to as the angle of inclination

**angle of depression:** the angle formed between the horizontal and the line of sight when looking downward



**Example 4**

The angle of elevation of Sandra's kite string is  $70^\circ$ . If she has let out 55 feet of string, and is holding the string 6 feet above the ground, how high is the kite?

**SOLUTION**

Sketch and label a diagram.

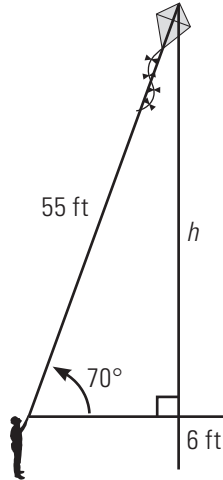

Use the sine ratio to solve for the height of the kite.

$$\sin H = \frac{\text{OPP}}{\text{hyp}}$$

$$\sin 70^\circ = \frac{h}{55} \quad \text{Substitute the known values.}$$

$$55 \times \sin 70^\circ = \frac{h}{55} \times 55 \quad \text{Multiply both sides by 55.}$$

$$55 \times \sin 70^\circ = h$$

$$51.7 \approx h$$

The kite is approximately 52 feet above where Sandra is holding it. Add 6 feet for the distance between the ground and the start of the string. The kite is about 58 feet above the ground.

**BUILD YOUR SKILLS**

10. George is in a hot air balloon that is 125 metres high. The angle of elevation from a house below, to the balloon, is  $18^\circ$ . How far is George from the house?
11. The angle of elevation of a road is  $4.5^\circ$ . What is the length of the section of road if it rises 16 metres?
12. The angle of elevation of a slide that is 3.6 metres long is  $32^\circ$ . How high above the ground is the top of the slide?

**PRACTISE YOUR NEW SKILLS**

1. Calculate the sine of the indicated angle.

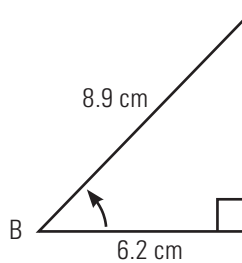
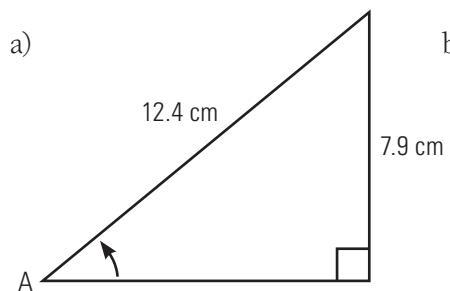

2. Calculate the length of the indicated side.

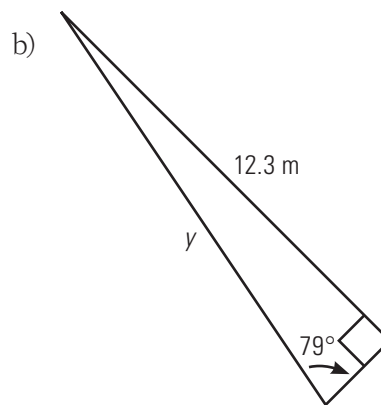
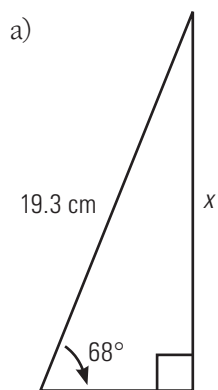



## 7.3

## The Cosine Ratio

## NEW SKILLS: WORKING WITH THE COSINE RATIO TO SOLVE TRIANGLES

**cosine ratio:** in a right triangle, the ratio of the length of the side adjacent a given angle to the length of the hypotenuse (abbreviated as cos)

Another important trigonometric ratio of right triangles is the ratio of the side adjacent to the given acute angle to the hypotenuse. This is called the **cosine ratio**.

For a given angle  $A$ , the cosine ratio can be stated as follows.

$$\cosine \angle A = \frac{\text{length of side adjacent to } \angle A}{\text{length of hypotenuse}}$$

This ratio can be abbreviated as follows.

$$\cos A = \frac{\text{adj}}{\text{hyp}}$$

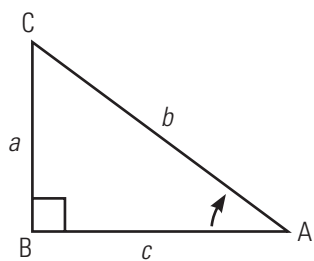

For triangle ABC, the cosine of  $\angle A$  can be stated as the following.

$$\cos A = \frac{c}{b}$$

For more details, see page 293 of *MathWorks 10*.

**Example 1**

Given the triangles below, find the indicated side.

a)

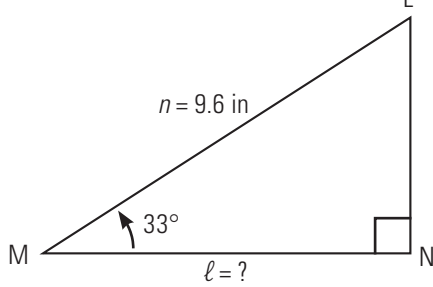

b)

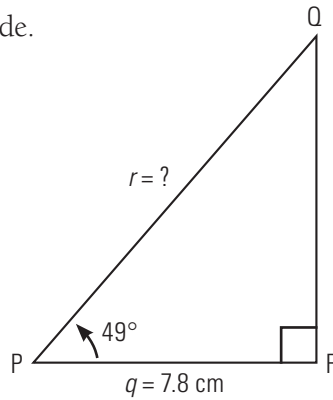
**SOLUTION**

a) Use the cosine ratio to solve for  $l$ .

$$\cos M = \frac{\text{adj}}{\text{hyp}}$$

$$\cos 33^\circ = \frac{l}{9.6} \quad \text{Substitute the known values.}$$

$$9.6 \times \cos 33^\circ = \frac{l}{9.6} \times 9.6 \quad \text{Multiply both sides by 9.6 to isolate } l.$$

$$9.6 \cos 33^\circ = l \quad \text{Simplify.}$$

$$8.05 \approx l$$

The missing side is approximately 8.1 inches long.

**ALTERNATIVE SOLUTION**

a) Since you know that the sum of the angles of a triangle is  $180^\circ$ , you can calculate angle L and then use the sine ratio to solve for  $l$ .

$$180^\circ - 90^\circ - 33^\circ = 57^\circ$$

$$\sin L = \frac{\text{opp}}{\text{hyp}}$$

$$\sin 57^\circ = \frac{l}{9.6} \quad \text{Substitute the known values.}$$

$$9.6 \sin 57^\circ = \frac{l}{9.6} \times 9.6 \quad \text{Multiply both sides by 9.6 to isolate } l.$$

$$9.6 \sin 57^\circ = l$$

$$8.05 \approx l$$

Side  $l$  is approximately 8.1 inches long.

The notation  $9.6 \cos 33^\circ$ , without the multiplication symbol, can be used to mean  $9.6 \times \cos 33^\circ$ .

b) Use the cosine ratio to solve for  $r$ .

$$\cos P = \frac{\text{adj}}{\text{hyp}}$$

$$\cos 49^\circ = \frac{7.8}{r} \quad \text{Substitute the known values.}$$

$$r \cos 49^\circ = \frac{7.8}{r} \times r \quad \text{Multiply both sides by } r.$$

$$r \cos 49^\circ = 7.8 \quad \text{Simplify.}$$

$$\frac{r \cos 49^\circ}{\cos 49^\circ} = \frac{7.8}{\cos 49^\circ} \quad \text{Divide both sides by } \cos 49^\circ \text{ to isolate } r.$$

$$r \approx 11.89$$

Side  $r$  is approximately 11.9 cm long.

### BUILD YOUR SKILLS

1. Use your calculator to find the following pairs of ratios to four decimal places.

a)  $\cos 23^\circ =$

b)  $\cos 83^\circ =$

$\sin 67^\circ =$

$\sin 7^\circ =$

c)  $\cos 45^\circ =$

d)  $\cos 37^\circ =$

$\sin 45^\circ =$

$\sin 53^\circ =$

2. Find the measure of the indicated side in each triangle.

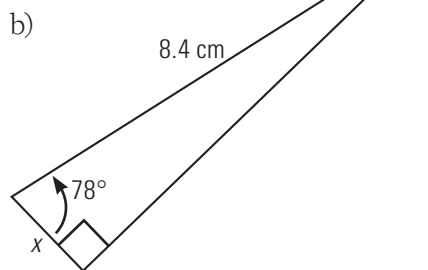
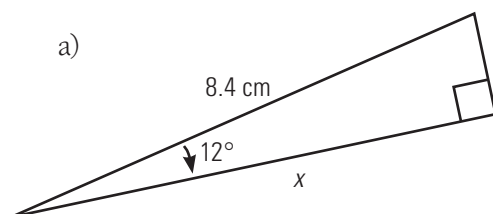

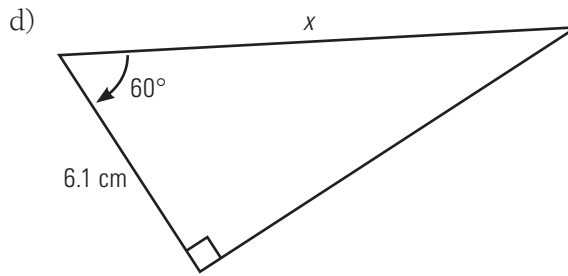
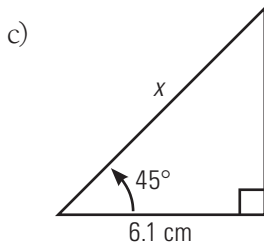

### Example 2

How far from the base of a house is a 40-foot ladder if the angle of elevation is 72°?

#### SOLUTION

Sketch a diagram.

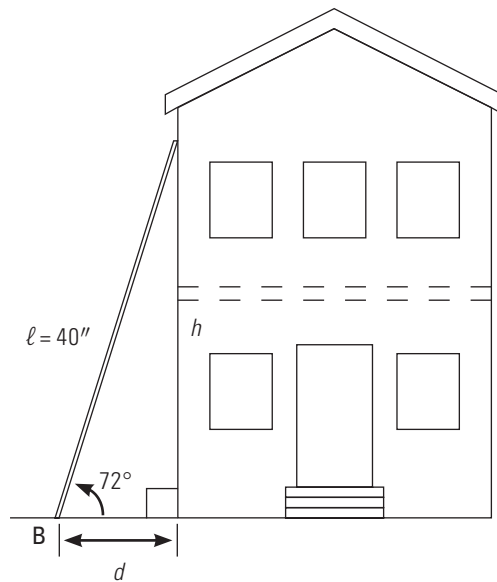

Use the cosine ratio to solve for  $d$ .

$$\cos B = \frac{\text{adj}}{\text{hyp}}$$

$$\cos B = \frac{d}{\ell}$$

$$\cos 72^\circ = \frac{d}{40} \quad \text{Substitute the known values.}$$

$$40 \cos 72^\circ = \frac{d}{40} \times 40 \quad \text{Multiply both sides by 40.}$$

$$40 \cos 72^\circ = d \quad \text{Simplify.}$$

$$12.36 \approx d$$

The ladder rests about 12.4 feet from the house.



**BUILD YOUR SKILLS**

3. How far from the base of a flagpole must a guy wire be fixed if the wire is 12 metres long and it makes an angle of  $63^\circ$  with the ground?
4. Reba walks 25 yards across the diagonal of a rectangular field. If the angle between the width and the diagonal is  $67^\circ$ , how wide is the field?
5. A square pyramid has a slant height of 9 metres. The slant height makes an angle of  $70^\circ$  with the ground. What is the length of a side of the pyramid?

**Example 3**

The angle of a cable from a point 12.5 metres from its base is  $52^\circ$ . How long is the cable?

**SOLUTION**

Sketch a diagram.

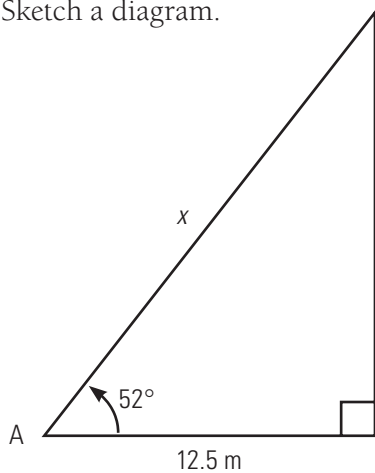

Use the cosine ratio to solve for  $x$ , the length of the cable.

$$\cos A = \frac{\text{adj}}{\text{hyp}}$$

$$\cos 52^\circ = \frac{12.5}{x} \quad \text{Substitute the known values.}$$

$$x \cos 52^\circ = \frac{12.5}{x} \times x \quad \text{Multiply both sides by } x.$$

$$x \cos 52^\circ = 12.5 \quad \text{Simplify.}$$

$$\frac{x \cos 52^\circ}{\cos 52^\circ} = \frac{12.5}{\cos 52^\circ} \quad \text{Divide both sides by } \cos 52^\circ \text{ to isolate } x.$$

$$x = \frac{12.5}{\cos 52^\circ}$$

$$x \approx 20.30$$

The cable is approximately 20.3 metres long.

**BUILD YOUR SKILLS**

6. Arul needs to string a bridge line across the river from A to B. What must the length of the bridge line be, given his measurements?

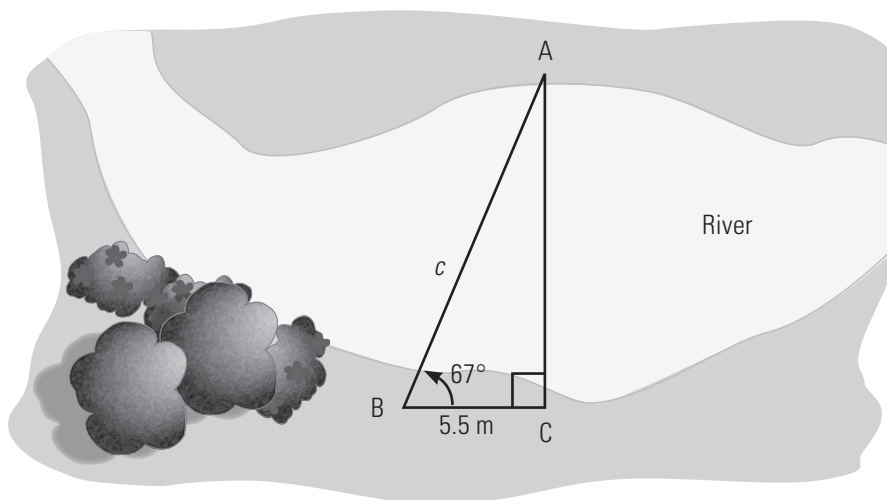

7. What is the length of a rafter that makes an angle of  $35^\circ$  with the floor of an attic whose centre is  $9.5$  metres from the edge?

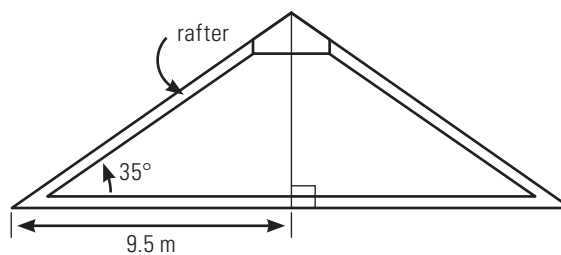

8. An airplane starts descending at an angle of depression of  $5^\circ$ . If the horizontal distance to its destination is 500 kilometres, what is the actual distance the airplane will travel before it lands?

### PRACTISE YOUR NEW SKILLS

1. Find the lengths of the indicated sides.

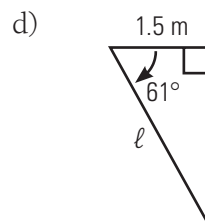
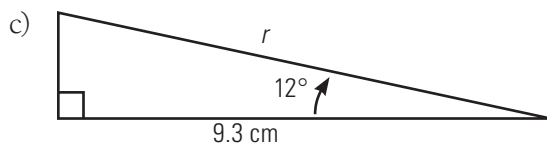
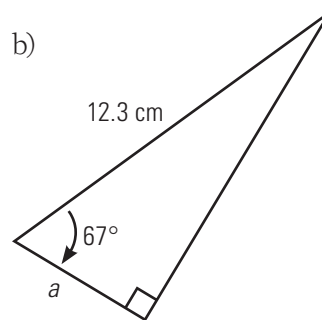
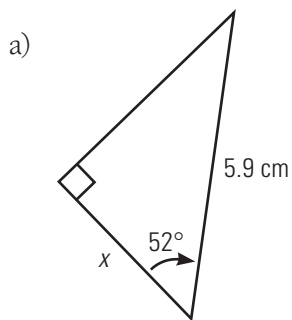



5. What horizontal distance has a car travelled if the incline of the road averages  $3.2^\circ$  and the car's odometer reads 8.5 kilometres?
6. The horizontal distance between two clothesline poles is 3.4 metres. When wet clothes are hung in the middle of the line, it sags at an angle of depression of  $6^\circ$ . How long is the clothesline?

## 7.4

## The Tangent Ratio

## NEW SKILLS: WORKING WITH THE TANGENT RATIO TO SOLVE TRIANGLES

**tangent ratio:** in a right triangle, the ratio of the length of the side opposite a given angle to the length of the side adjacent to the angle (abbreviated as tan)

You have studied two trigonometric ratios, the sine ratio and the cosine ratio. The third trigonometric ratio is the **tangent ratio**.

The tangent ratio is defined as the ratio of the side opposite an acute angle of a right triangle to the side adjacent the angle. For angle A, the ratio can be stated as follows.

$$\text{tangent } \angle A = \frac{\text{length of side opposite } \angle A}{\text{length of side adjacent to } \angle A}$$

This can be abbreviated as the following ratio.

$$\tan A = \frac{\text{opp}}{\text{adj}}$$

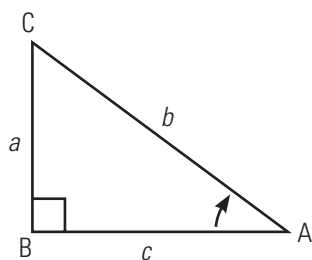

For triangle ABC, the tangent of angle A can be stated as follows.

$$\tan A = \frac{a}{c}$$

For more details, see page 301 of *MathWorks 10*.

**Example 1**

Find the indicated side of each triangle.

a)

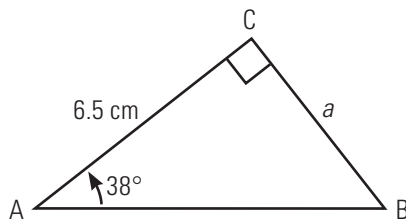

b)

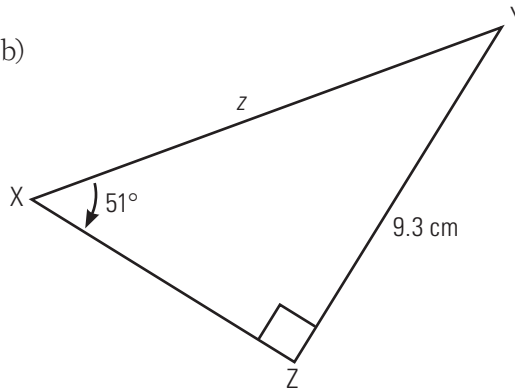
**SOLUTION**

a) Use the tangent ratio to solve for  $a$ .

$$\tan A = \frac{\text{opp}}{\text{adj}}$$

$$\tan 38^\circ = \frac{a}{6.5} \quad \text{Substitute the known values.}$$

$$6.5 \tan 38^\circ = \frac{a}{6.5} \times 6.5 \quad \text{Multiply both sides by } \tan 6.5 \text{ to isolate } a.$$

$$6.5 \tan 38^\circ = a$$

$$5.08 \approx a$$

Side  $a$  is approximately 5.1 centimetres long.

b) Use the tangent ratio to solve for  $z$ .

$$\tan X = \frac{\text{opp}}{\text{adj}}$$

$$\tan 51^\circ = \frac{9.3}{z} \quad \text{Substitute the known values.}$$

$$z \tan 51^\circ = 9.3 \quad \text{Multiply both sides by } z.$$

$$\frac{z \tan 51^\circ}{\tan 51^\circ} = \frac{9.3}{\tan 51^\circ} \quad \text{Divide both sides by } \tan 51^\circ \text{ to isolate } z.$$

$$z = \frac{9.3}{\tan 51^\circ}$$

$$z \approx 7.53$$

Side  $z$  is approximately 7.5 centimetres long.



**BUILD YOUR SKILLS**

1. Find the length of the indicated sides of the triangles.

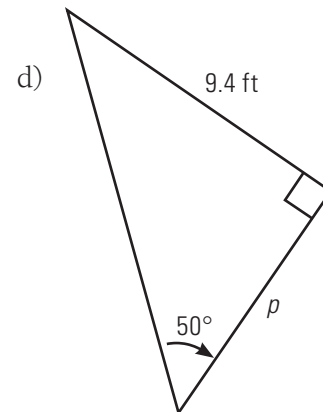
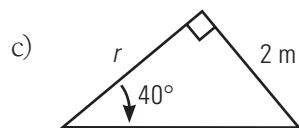
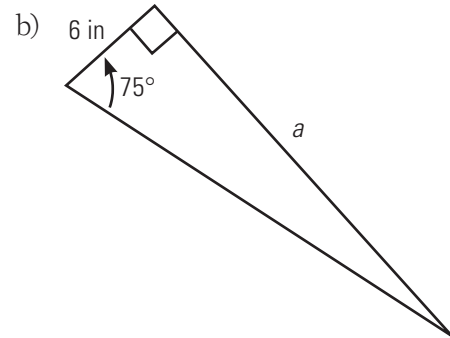
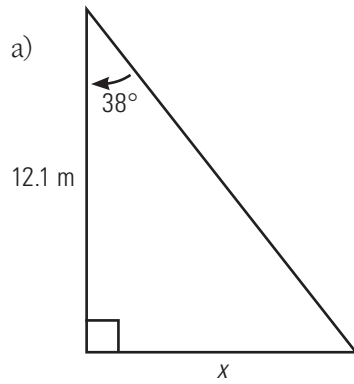

2. The angle of depression to a boat from the top of a 150-metre cliff is  $20^\circ$ . How far is the boat from the base of the cliff?

3. When sand is piled onto a flat surface, it forms a cone. If the pile is 8 m wide, and the angle between the ground and the slope of the pile is  $28^\circ$ , what is the height of the pile?

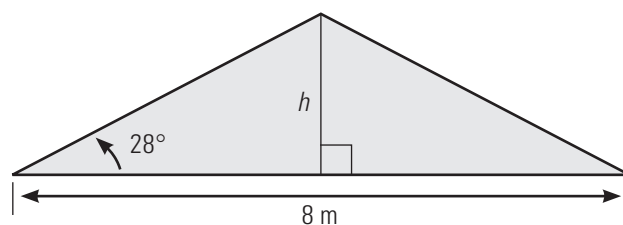
**PRACTISE YOUR NEW SKILLS**

1. A 1.7-metre tall man stands 12 m from the base of a tree. He views the top of the tree at an angle of elevation of  $58^\circ$ . How tall is the tree?



5. A rafter's angle of elevation with the horizontal is  $25^\circ$ . How far from the corner could a 6-foot man stand up straight?

6. Determine the distance,  $AB$ , across the river, given the following measurements.

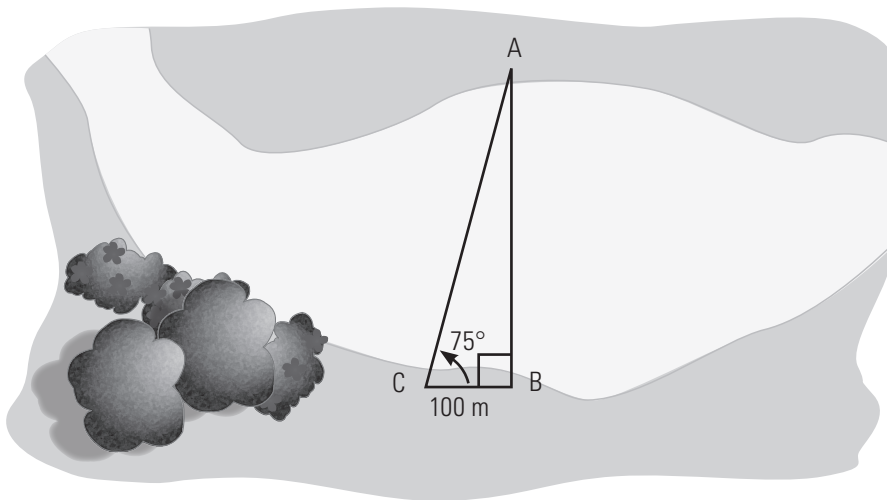

## 7.5

## Finding Angles and Solving Right Triangles

**NEW SKILLS: WORKING WITH INVERSE TRIGONOMETRIC RATIOS**

The trigonometric ratios discussed in this chapter are unaffected by the size of the triangle, provided that the acute angle remains the same.

If you know the trigonometric ratio, you can calculate the size of the angle. This requires an “inverse” operation. You can use your calculator to find the opposite of the usual ratio calculation. You can think of the inverse in terms of subtraction and addition: subtraction is the inverse, or opposite, of addition because it “undoes” the operation.

For more details, see page 307 of *MathWorks 10*.

**Example 1**

Calculate each angle to the nearest degree.

- a)  $\sin A = 0.2546$
- b)  $\cos B = 0.1598$
- c)  $\tan C = 3.2785$

**SOLUTION**

Use the inverse function on your calculator.

a)  $\sin A = 0.2546$

$$A = \sin^{-1}(0.2546)$$

$$A \approx 14.7$$

$\angle A$  is approximately  $15^\circ$ .

b)  $\cos B = 0.1598$

$$B = \cos^{-1}(0.1598)$$

$$B \approx 80.8$$

$\angle B$  is approximately  $81^\circ$ .

c)  $\tan C = 3.2785$

$$C = \tan^{-1}(3.2785)$$

$$C \approx 73.0$$

$\angle C$  is approximately  $73^\circ$ .

**BUILD YOUR SKILLS**

1. Calculate the angle to the nearest degree.

a)  $\sin D = 0.5491$

b)  $\cos F = 0.8964$

c)  $\tan G = 2.3548$

d)  $\sin H = 0.9998$

2. In right triangle  $\triangle XYZ$ , the ratio of the side opposite  $\angle X$  to the hypotenuse is  $\frac{7}{8}$ .  
What is the approximate size of  $\angle X$ ?

When solving this problem on your calculator, put brackets around  $\frac{7}{8}$ .

3. What is the approximate size of an angle in a right triangle if the ratio of the side opposite the angle to the side adjacent to the angle is  $\frac{15}{8}$ ?

**Example 2**

Determine the angle of elevation to the top of a 5-metre tree at a point 3 metres from the base of the tree.

**SOLUTION**

Sketch a diagram.

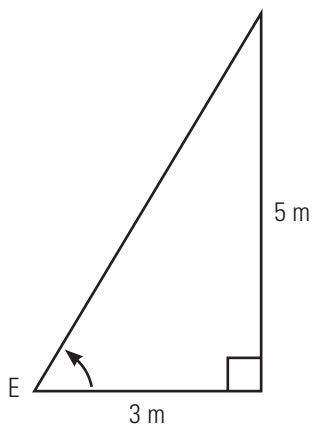

When solving this problem on your calculator, put brackets around  $\frac{5}{3}$ .

You are given the height ( $h$ , 5 metres) and the length ( $\ell$ , 3 metres) of the triangle, and you need to solve for the angle of elevation. Use the tangent ratio.

$$\tan E = \frac{\text{opp}}{\text{adj}}$$

$$\tan E = \frac{5}{3} \quad \text{Substitute the known values.}$$

$$E = \tan^{-1}\left(\frac{5}{3}\right) \quad \text{Use the inverse function to solve for } E.$$

$$E \approx 59.0362$$

The angle of elevation is approximately  $59^\circ$ .

**BUILD YOUR SKILLS**

4. What is the angle of depression from the top of a 65-metre cliff to an object 48 metres from its base?
5. At what angle to the ground must you place a support if it is 6.8 metres long and must reach 4.2 metres up the side of a tower?
6. At what angle to the ground is an 8-metre long conveyor belt if it is fastened 5 metres from the base of a loading ramp?

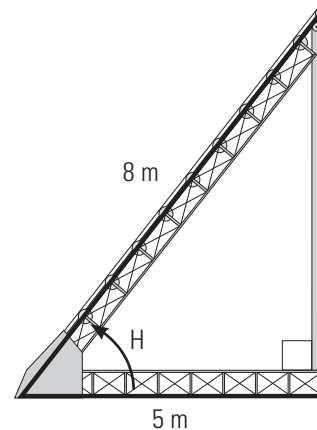



## NEW SKILLS: WORKING WITH RATIOS TO SOLVE TRIANGLES

Solving a triangle means finding the values of all the unknown sides and angles. In a right triangle, you already know that one angle is  $90^\circ$ , so there are only five other parts to consider: the three sides, and the two other angles. If you are given any two sides, or any one side and one angle, you can use trigonometry to find the other values.

### Example 3

Solve the right triangle. Give lengths to the nearest tenth.

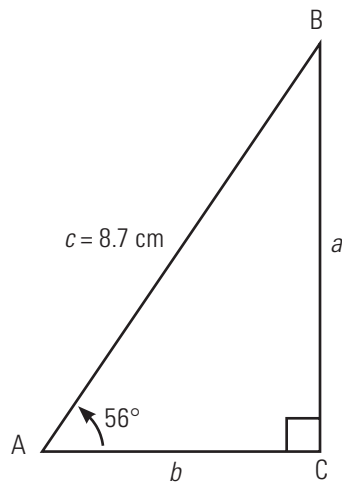

### SOLUTION

You are given two of the three angles, so you can solve for the third angle.

$$\angle B = 180^\circ - 90^\circ - 56^\circ$$

$$\angle B = 34^\circ$$

To solve for side  $a$ , you can use the sine ratio. Use  $\angle A$ , and the length of the hypotenuse,  $c$ .

$$\sin A = \frac{\text{opp}}{\text{hyp}}$$

$$\sin A = \frac{a}{c}$$

$$\sin 56^\circ = \frac{a}{8.7} \quad \text{Substitute the known values.}$$

$$8.7 \sin 56^\circ = \frac{a}{8.7} \times 8.7 \quad \text{Multiply both sides by 8.7 to isolate } a.$$

$$7.2126 \approx a$$

Side  $a$  is approximately 7.2 cm long.

To solve for  $b$ , use the cosine ratio.

$$\cos A = \frac{\text{adj}}{\text{hyp}}$$

$$\cos A = \frac{b}{c}$$

$$\cos 56^\circ = \frac{b}{8.7} \quad \text{Substitute the known values.}$$

$$8.7 \cos 56^\circ = \frac{b}{8.7} \times 8.7 \quad \text{Multiply both sides by 8.7 to isolate } b.$$

$$8.7 \cos 56^\circ = b \quad \text{Simplify.}$$

$$4.8650 \approx b$$

Side  $b$  is approximately 4.9 cm long.

### BUILD YOUR SKILLS

7. Solve the given triangle without using the Pythagorean theorem.

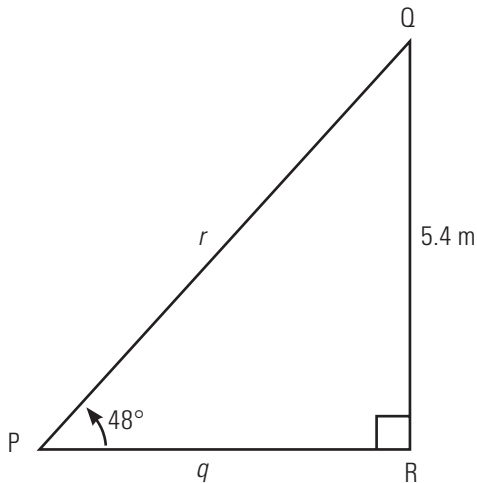

You could have used the Pythagorean theorem to find side  $b$ , but this would have been less accurate because you would have used an approximation for side  $a$ . It is always better to use the numbers given, if possible, rather than one you calculated.

8. The two equal angles of an isosceles triangle are each  $70^\circ$ . Determine the measures of the rest of the triangle if it has a height of 16 cm.

9. The length of the rafter is 5.5 yards, and the side height of the building is 3.5 yards. Determine the width of the building and its total height.

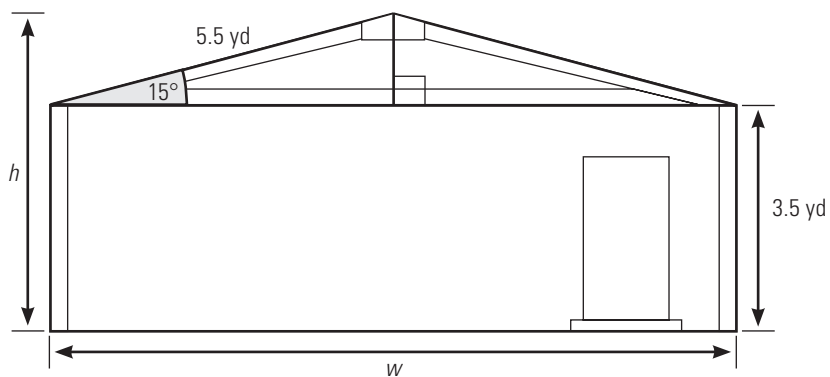

**Example 4**

Solve the given triangle.

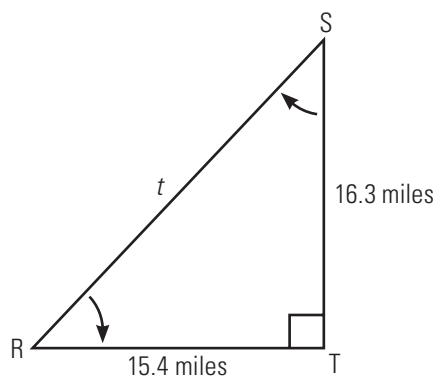
**SOLUTION**

Calculate  $\angle R$  using the tangent ratio.

$$\tan R = \frac{\text{opp}}{\text{adj}}$$

$$\tan R = \frac{ST}{TR}$$

$$\tan R = \frac{16.3}{15.4} \quad \text{Substitute the known values.}$$

$$\angle R = \tan^{-1}\left(\frac{16.3}{15.4}\right) \quad \text{Use the inverse function to solve for } \angle R.$$

$$\angle R \approx 46.6263$$

$\angle R$  is approximately  $47^\circ$ .

Calculate  $\angle S$  using the measures of the angles in the triangle.

$$\angle S = 180^\circ - 90^\circ - 47^\circ$$

$$\angle S = 43^\circ$$

Calculate the length of side  $t$  using the Pythagorean theorem.

$$r^2 + s^2 = t^2$$

$$16.3^2 + 15.4^2 = t^2$$

$$\sqrt{16.3^2 + 15.4^2} = t$$

$$\sqrt{265.69 + 237.16} = t$$

$$\sqrt{502.85} = t$$

$$22.42 \approx t$$

Side  $t$  is approximately 22.4 miles long.

You could have found  $\angle S$  first using the tangent ratio.

You could have solved for side  $t$  using the sine or cosine functions, but this would have involved rounding errors.

**BUILD YOUR SKILLS**

10. Solve the following triangles.

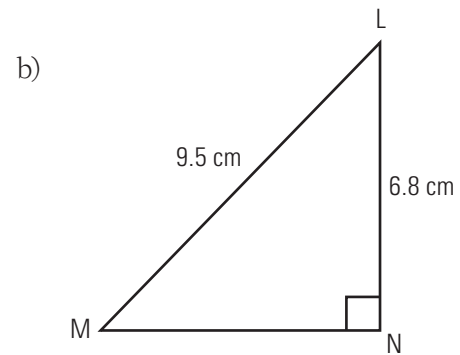
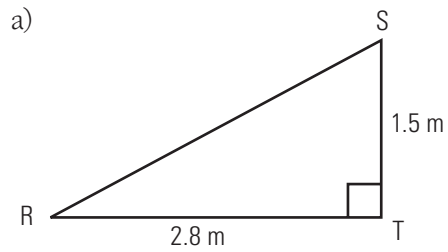

11. What height is a pole, and how far away from it is a cable attached to the ground, if the angle of elevation is  $25^\circ$  and the cable is 18 m long?

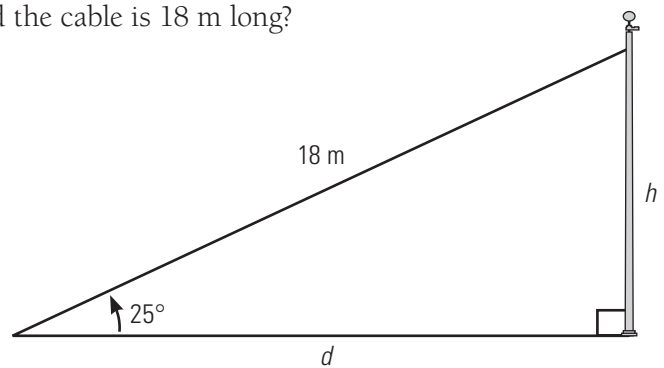

12. Find the values of  $a$ ,  $b$ ,  $c$ , and  $d$ .

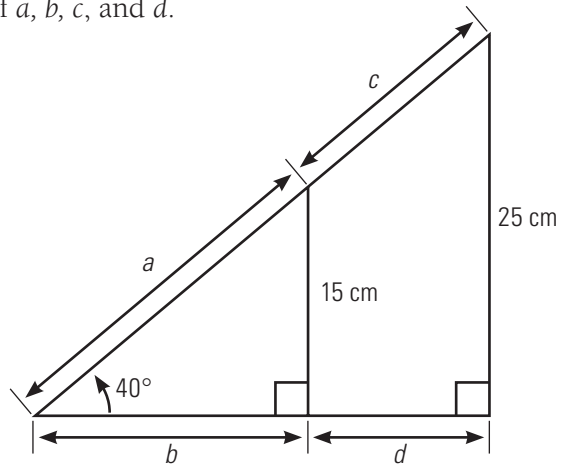

### PRACTISE YOUR NEW SKILLS

1. Find the indicated angle in each of the following diagrams.

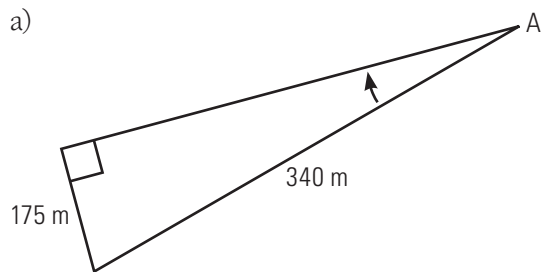







**CHAPTER TEST**

1. What is the length of a diagonal brace used to support a table that is 120 cm wide by 50 cm tall?

2. The Pyramid of Khufu is approximately 140 metres tall. If the base is a square with sides measuring 230 metres, what is the slant height from the centre of one of the sides of the pyramid? (Hint the slant height is the hypotenuse of a right triangle.)

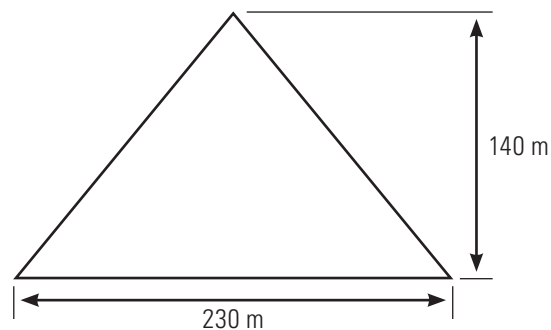

3. A plane travels 12 km along its flight path while climbing at a constant rate of  $8^\circ$ . What is the vertical change in height during this time?



7. The angle of elevation from the bottom of one building to the top of another building is  $78^\circ$ . The angle of elevation from the bottom of the second building to the top of the first is  $62^\circ$ . If the distance between them is 150 metres, how much taller is the higher building than the shorter one?

8. In an A-frame building, the angle of elevation of the roof is  $50^\circ$  and the building is 12 metres wide.

- a) How high is the building at the centre?

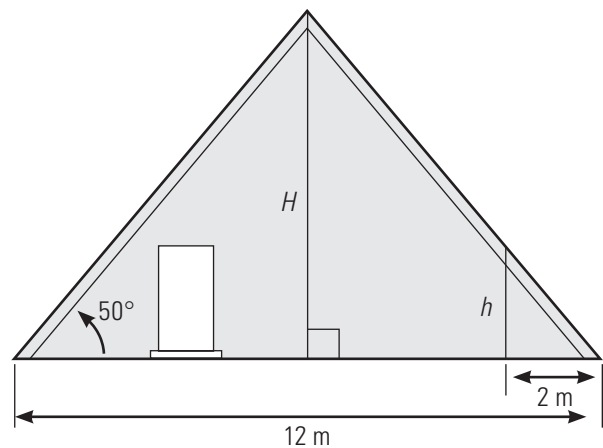

- b) How high is it 2 metres in from an edge?

9. A box is 1.5 m long, 1.0 m deep, and 8.0 m tall. What is the length of the longest object that can fit in the box?

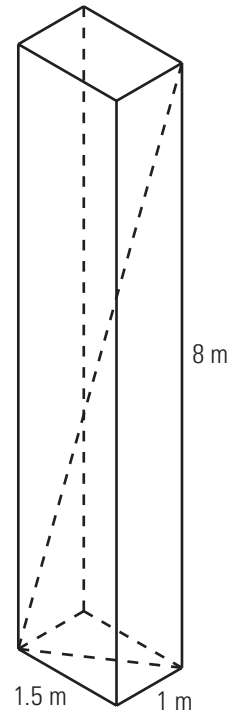

10. A lifeguard sits in a chair that is 2.5 metres high. He spots a child in trouble in the water at an angle of depression of  $23^\circ$ . How far out from the chair is the child?

11. What is the angle of elevation of a playground slide that is 1.2 m high and has a horizontal length of 2.6 m?

# Glossary

**alternate exterior angles:** angles in opposite positions outside two lines intersected by a transversal

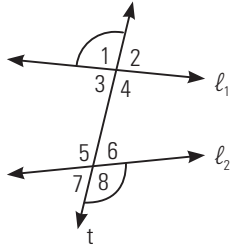

**alternate interior angles:** angles in opposite positions between two lines intersected by a transversal and also on alternate sides of the same transversal

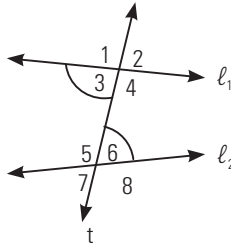

**angle bisector:** a segment, ray, or line that separates two halves of a bisected angle

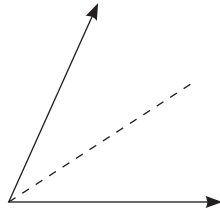

**angle of depression:** the angle formed between the horizontal and the line of sight while looking downward

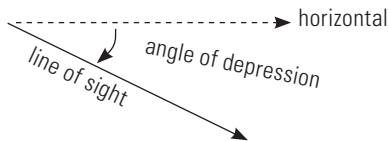

**angle of elevation:** the angle formed between the horizontal and the line of sight when looking upward; sometimes referred to as the angle of inclination

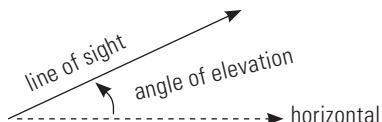

**capacity:** the maximum amount that a container can hold

**circumference:** the measure of the perimeter of a circle

**complementary angles:** two angles that have measures that add up to  $90^\circ$

**corresponding angles:** two angles that occupy the same relative position at two different intersections

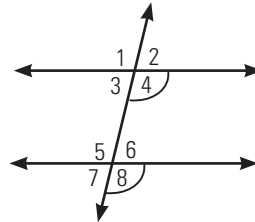

**corresponding sides:** two sides that occupy the same relative position in similar figures

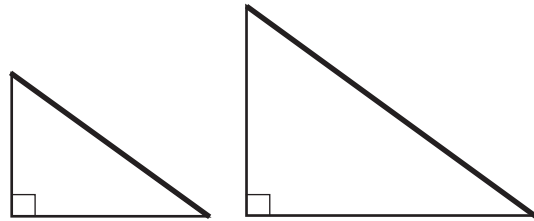

**cosine ratio:** in a right triangle, the ratio of the length of the side adjacent to a given angle to the length of the hypotenuse (abbreviated as cos)

**deduction:** money taken off your paycheque to pay taxes, union fees, and for other benefits and programs

**divisor:** in a division operation, the number by which another number is divided; in  $a \div b = c$ ,  $b$  is the divisor

**exchange rate:** the price of one country's currency in terms of another country's currency

**factor:** one of two or more numbers that, when multiplied together, form a product. For example, 1, 2, 3, and 6 are factors of the product 6 because:

$$1 \times 6 = 6$$

$$2 \times 3 = 6$$

$$3 \times 2 = 6$$

$$6 \times 1 = 6$$

**gross pay:** the total amount of money earned before deductions; also called gross earnings or gross income

**hypotenuse:** the longest side of a triangle, opposite the  $90^\circ$  angle

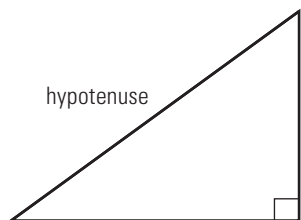

**imperial system:** the system most commonly used in the United States; the standard unit of measurement for length is the foot

**kilogram:** the mass of one litre of water at  $4^\circ\text{C}$

**markup:** the difference between the amount a dealer sells a product for (retail price) and the amount he or she paid for it (wholesale price)

**mass:** a measure of the quantity of matter in an object

**multiple:** the product of a number and any other number. For example, 2, 4, 6, and 8 are some multiples of 2 because:

$$2 \times 1 = 2$$

$$2 \times 2 = 4$$

$$2 \times 3 = 6$$

$$2 \times 4 = 8$$

**net:** a two-dimensional pattern used to construct three-dimensional shapes

**net income:** income after all taxes and other deductions have been applied; also called take-home pay

**percentage:** a ratio with a denominator of 100; percent (%) means "out of 100"

**perimeter:** the sum of the lengths of all the sides of a polygon

**promotion:** an activity that increases awareness of a product or attracts customers

**proportion:** a fractional statement of equality between two ratios or rates

**Pythagorean theorem:** in a right triangle, the sum of the squares of the lengths of the legs is equal to the square of the length of the hypotenuse

**quotient:** the result of a division; in  $a \div b = c$ ,  $c$  is the quotient

**rate:** a comparison between two numbers measured with different units

**ratio:** a comparison between two numbers measured in the same units

**sine ratio:** in a right triangle, the ratio of the length of the side opposite a given angle to the length of the hypotenuse (abbreviated as sin)

**supplementary angles:** two angles that have measures that add up to  $180^\circ$

**surface area:** the total area of all the faces, or surfaces, of a three-dimensional object; measured in square units

**Système International (SI):** the modern version of the metric system; uses the metre as the basic unit of length

**tangent ratio:** in a right triangle, the ratio of the length of the side opposite a given angle to the length of the side adjacent to the angle (abbreviated as tan)

**taxable income:** income after before-tax deductions have been applied, on which federal and provincial taxes are paid

**transversal:** a line that intersects two or more lines

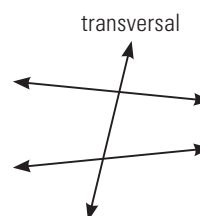

**true bearing:** the angle measured clockwise between true north and an intended path or direction, expressed in degrees

**unit price:** the cost of one unit; a rate expressed as a fraction in which the denominator is 1

**vertically opposite angles:** angles created by intersecting lines that share only a vertex

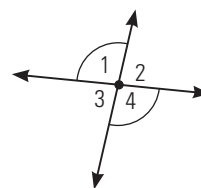

**volume:** the amount of space an object occupies

**weight:** a measure of the force of gravity on an object